



Oklahoma City Urban Renewal Authority (OCURA) *Northeast* Residential Design Standards

Oklahoma City, Oklahoma • March, 25th 2015

Acknowledgements

The Oklahoma City Urban Renewal Authority (OCURA), a partnering agency of the **Alliance for Economic Development of Oklahoma City**

Catherine O'Connor, President and CEO of the Alliance; Executive Director of OCURA

Denise M. Balkas, AICP, COO/VP of Operations for the Alliance

Cassi Poor, LEED AP BD+C, CNU-A , Project Manager for the Alliance

Bob Begle, Principal, Lord Aeck Sargent

John Skach, Senior Associate, Lord Aeck Sargent

Jessica Florez, Urban Designer, Lord Aeck Sargent

OCURA would like to thank stakeholders and builders from neighborhoods located in northeast Oklahoma City for their valuable input.

Oklahoma City Urban Renewal Authority (OCURA) *Northeast* Residential Design Standards

Oklahoma City, Oklahoma
March 25th, 2015

Prepared for:

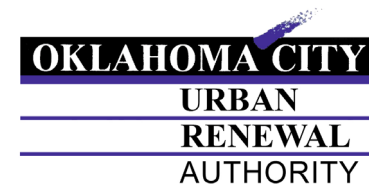

Oklahoma City Urban Renewal Authority (OCURA) /
The Alliance for Economic Development of Oklahoma City, Inc.
105 N. Hudson, Suite 101
Oklahoma City, OK 73102
Office: 405-604-6780

www.ocura-ok.org
www.theallianceokc.org

Prepared by:

LORD
AECK
SARGENT

Table of Contents

Introduction

1. The Design Context

1.1 Neighborhood Evolution

Subdivision & Streetcars
Community Builders & Pattern Books
Depression & War
Postwar to Postmodern
Recent Developments

1.2 Existing Architectural Categories

The Streetcar Suburban House: Bungalow, American Foursquare, National, Two-Family Dwellings
The Catalogue House: Craftsman Cottage, Tudor Revival
The Minimal Traditional House
The Modern House: Ranches
The Postmodern House: The New Eclectic, The Contemporary

2. Architectural & Site Design Guidelines

2.1 Site Planning Standards

2.2 Architectural Standards

3. The Design Review Process

3.1 Choosing Your Architectural Category

3.2 Design Review

Appendix



1320

Introduction

Introduction

The Oklahoma City Urban Renewal Authority (OCURA) is committed to delivering architecturally compatible, affordable and market rate housing options in northeast Oklahoma City. OCURA's portfolio of land provides many opportunities to work with nonprofits, the City of Oklahoma City, and the private sector to achieve this goal. This manual represents one of the building blocks needed to construct and renovate housing.

OCURA has historically required design review for all of its projects. In terms of housing, it has adopted various design review standards over the years.

This handbook was envisioned to refresh existing design standards and progress to a higher level of neighborhood planning and infill development. Infill development is challenging given that new and renovated housing products must be compatible within an established neighborhood context yet the housing market is constantly introducing new design and amenity concepts to appeal to buyers. The goal of this handbook is to achieve all of these objectives through design and site planning standards.

The staff of OCURA is committed to working with prospective developers, builders and existing property owners to deliver housing that will bring new residents to Northeast Oklahoma City and increase property values for existing property owners.

These standards apply to the Study Area delineated in red in Figure 0.1. The area is generally bound by N.E. 23rd St., I-35 Hwy., N.E. 10th St., N. Martin Luther King Ave., N.E. 4th St., N. Stonewall Ave. and N. Lottie Ave.

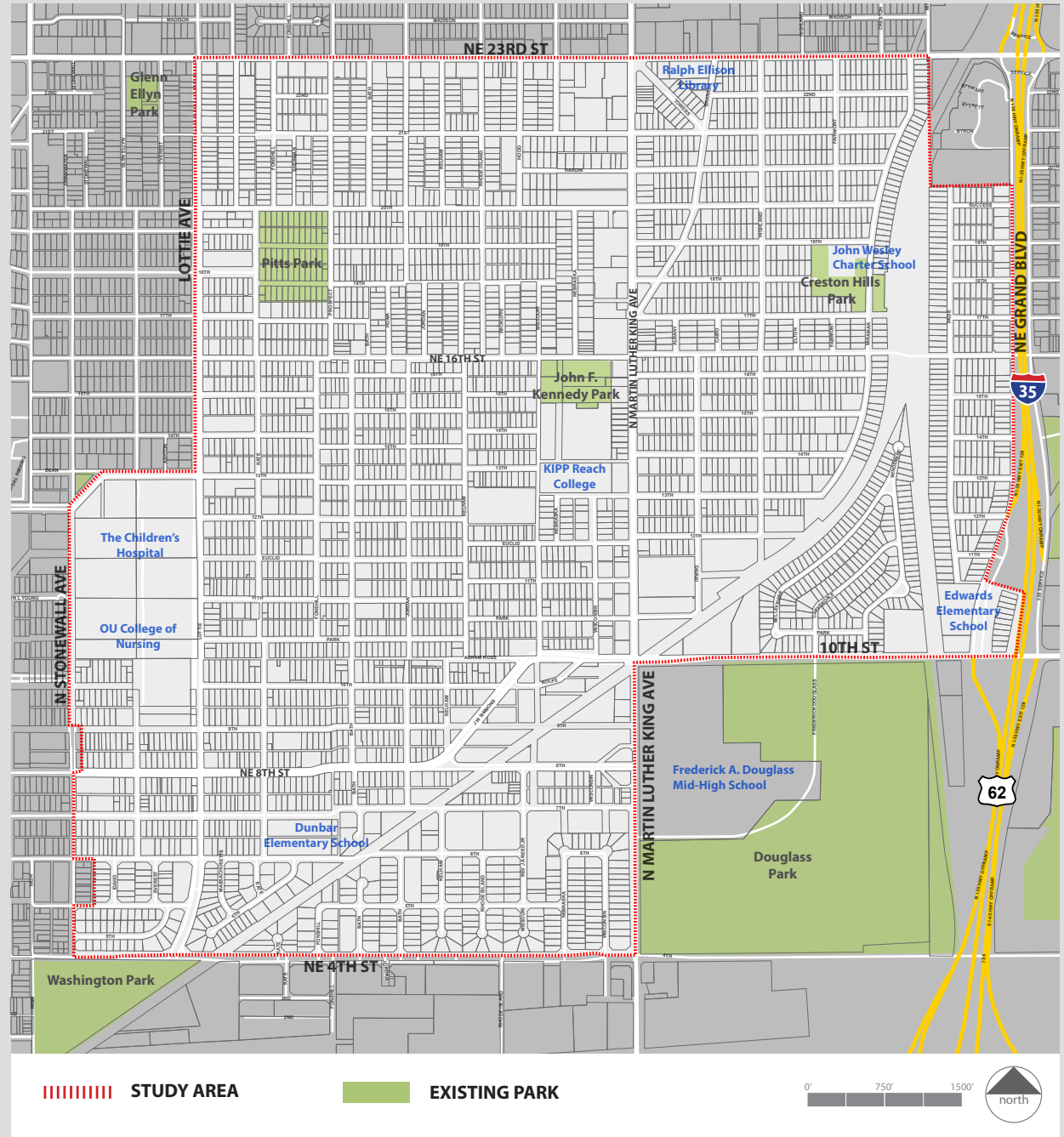

FIGURE 0.1



A historical black and white photograph of an oil field town. In the foreground, a dirt road runs diagonally from the bottom left towards the center. A wooden fence lines the left side of the road. On the right side of the road, there are several buildings, including a large house with a porch and a smaller structure. A vintage truck with a flatbed trailer is parked on the dirt road. In the background, numerous oil derricks (pumps) are visible against a light sky. Power lines and utility poles stretch across the scene. A semi-transparent green banner is overlaid on the right side of the image, containing the text '1.0 The Design Context' in white.

1.0 The Design Context

1.1 Neighborhood Evolution

Oklahoma City is a young, modern city that literally sprouted up on the Great Plains over the span of only a few decades after the Land Run of 1889. Built on “unassigned land” in Indian Territory, the city was largely the product of intense land speculation and development at a key period in the evolution of the real estate and housing industry in the United States.

Before the 1889 land run, the city was primarily open grassland dotted with illegal homesteads. When the gates were thrown open, settlers quickly staked out claims by building rudimentary shelters and filing deeds with the General Land Office. The dimensions of their land grants followed the template established by the 1785 Land Ordinance, which was devised by Congress to organize settlement in the West after the Revolutionary War. The 1862 Homestead Act, which encouraged western expansion that set the precedent for the land run, followed the contours of the Ordinance’s Public Land Survey System (PLSS).

After 1889, the area of Oklahoma City corresponding to the Northeast neighborhoods was either military land or rural homesteads. As the demand for new residential areas increased with city growth, many of the homesteads and land grants were subdivided or platted into city “additions”. These took on unique names for purposes of marketing the lots to homeowners or small builders; and eventually some additions became memorialized as neighborhoods. The story of Culbertson’s East Highland, Ross Heights, Creston Hills and other Northeast places, outlined in the following pages, is the story of these additions and how they were influenced by local and national trends.



Image 1A: Birds-eye view of Oklahoma City in 1890 showing the original block pattern derived from the Public Land Survey System.



Image 1B: Settler encampments, 1889 Land Rush

THE PUBLIC LAND SURVEY SYSTEM

The system that governs the boundaries of public and private land west of the Appalachian Mountains is based on a grid of square townships, six miles on each side, bounded by north-south meridians and east-west range lines. Nested within each township are 36 sections (one mile square), and smaller subdivisions of quarter-sections (160 acres), sixteenth-sections (40 acres), and smaller. The phrase “40 acres and a mule” refers to the method of distribution of sixteenth-section parcels to freed slaves after the Civil War.



Image 1C: Subdivision framework of the Public Land Survey System showing the derivation of a 60' x 120' lot from a thirty-six square mile township.

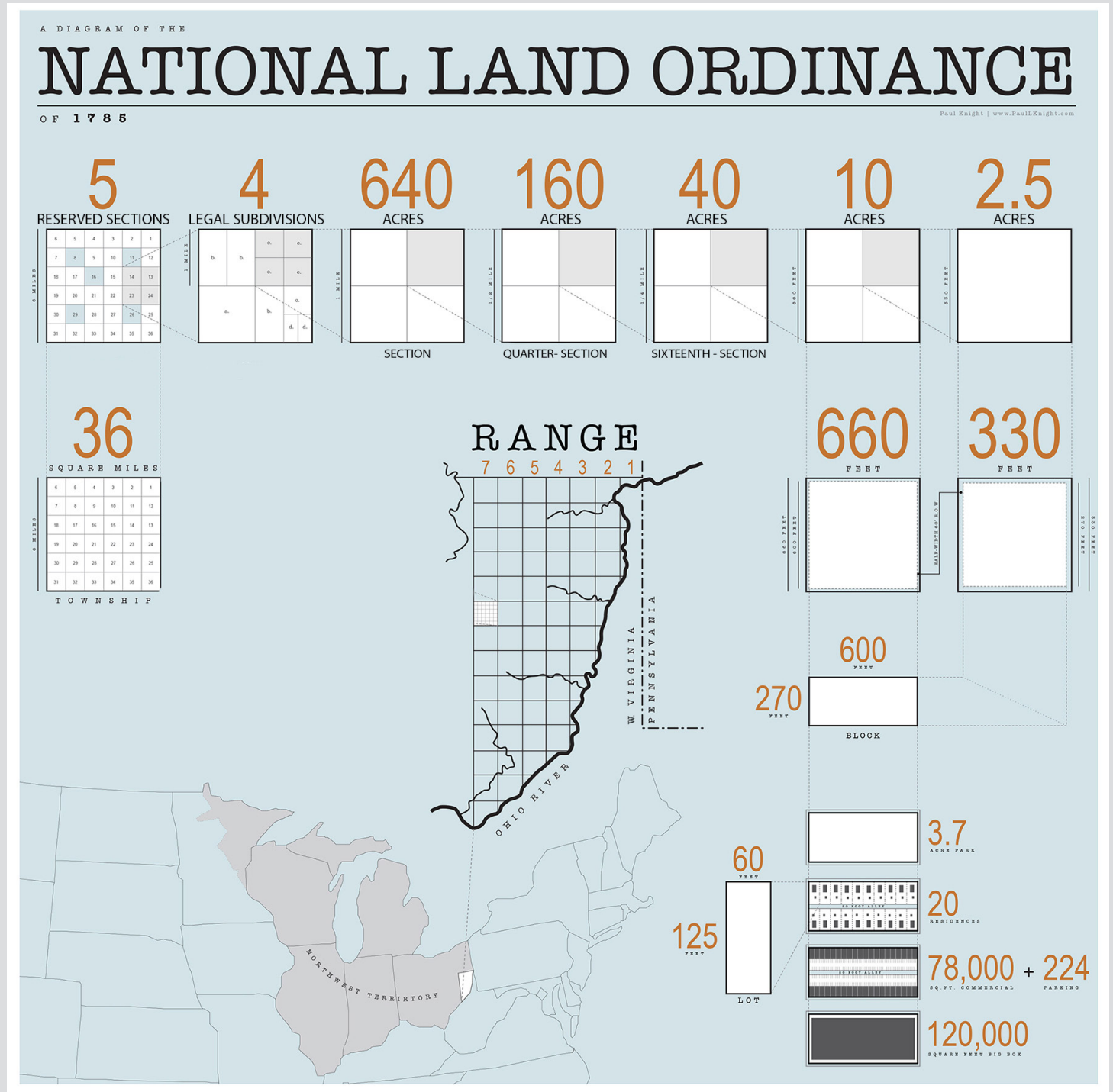

1.1 Neighborhood Evolution

1.1.1 Subdivision & Streetcars

Residential development in Northeast Oklahoma City began slowly. The Santa Fe railroad formed a physical barrier to the east of the central business district; and early neighborhoods were built to the north and west. It was not until the development of streetcar lines that new housing began to appear in the subdivided tracts east of downtown. Initially built as part of the John Shartel's Metropolitan Railway Company, the Harrison Avenue line through the Maywood Addition was extended into the Oak Park Addition shortly before 1908. The prospect of lucrative land sales fueled by speculation over streetcar construction resulted in other subdivision efforts in the Northeast including the quarter-section platting of Jordan Place / Park Place and Ross Heights; and the eighth-section platting of Bath Highland / Bath Orchard, Prospect Heights, and East Highland (on land owned by J. J. Culbertson).

Figure 1.1.1 illustrates the pattern of subdivision additions in 1908. Sections are indicated by the heavy black lines, with their PLSS identification numbers in each center. The lots shown in yellow correspond to "streetcar suburban" houses built up to approximately 1920. The Fairgrounds streetcar extension (1911) and the Capitol line (~1915) clearly have an effect on the location and intensity of house construction at this time. The sequence of images below is also indicative of the kind of housing built on these lots. Taken by Kathleen Mauck (top), they show her family's classic suburban bungalow at 1604 NE 9th in various stages of completion. This house was replaced with a modern duplex dwelling in 2009.



Image 1D: Garden view, 1604 NE 9th Street

JOHN JAMES CULBERTSON

J. J. Culbertson was born in Cincinnati in 1853. After working as a cotton product salesman for several years, he opened the first cottonseed oil mill in Paris, Texas in 1884 and eventually built a cotton oil empire. He invested in Oklahoma City real estate with his partner William Harn, even though he never lived in the city.



Image 1E: Construction sequence of 1604 NE 9th Street, early 1900s



Additions - 1908

1. OAK PARK
2. PARK PLACE
3. JORDAN PLACE
4. ROSS HEIGHTS
5. PROSPECT HEIGHTS
6. EAST HIGHLAND
7. BATH HIGHLAND
8. BATH ORCHARD
9. EASTVIEW / EDGEMONT

Image 1F: Entrance to fairgrounds showing streetcar loop, 1915

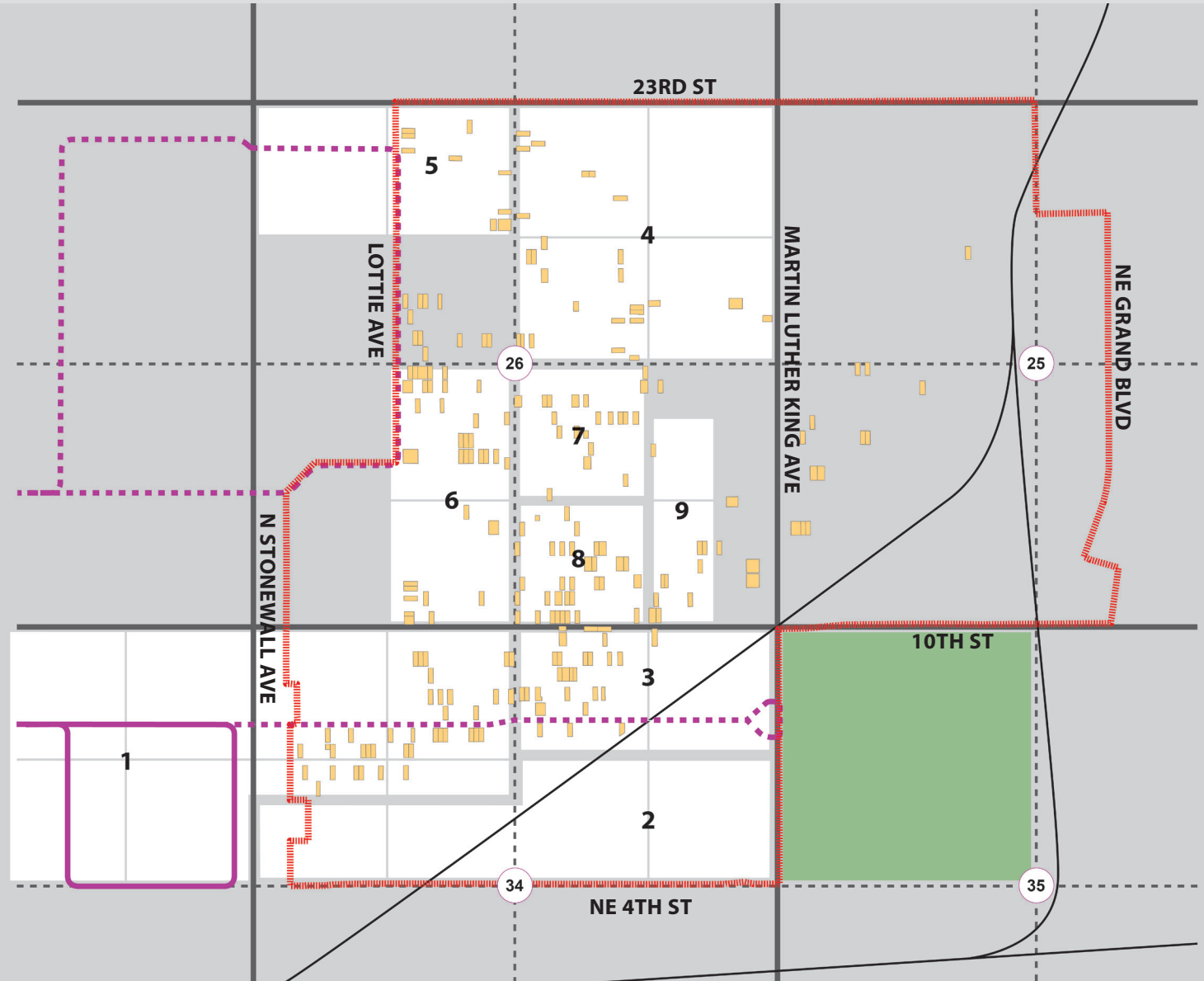
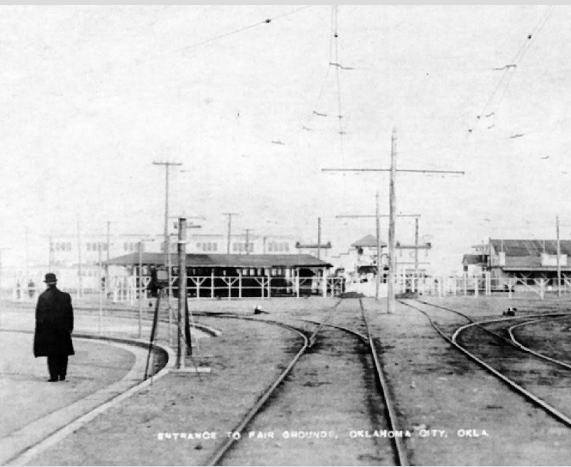

FIGURE 1.1.1

1.1 Neighborhood Evolution

1.1.2 Community Builders & Pattern Books

Three events in and around the 1920s changed the dynamics of housing growth in Northeast Oklahoma City that had ramifications felt even today: the establishment of the Medical College in 1918, the construction of the Capitol building in 1919, and the oil boom of 1928. Up until the 1920s, house construction was intermittent and scattered; but with the newfound wealth from high-value jobs, demand for modern, fashionable homes increased. This was also the golden era of pre-manufactured housing, and the rise of real estate developers, or “community builders”, that merged simple subdivision with city planning principles and design consistency. House catalogues from companies like Sears, Aladdin, and Pacific Homes popularized styles like Tudor Revival; and architects often reinterpreted the styles in unique ways such as in the design of Wescott Court on NE 20th and North Lottie Avenue, shown below.

While the subdivisions platted before World War I experienced new house construction in catalogue versions of either California-style Craftsman or Arts & Crafts / English cottages (shown in orange and red in Figure 1.1.2), the most noteworthy addition came in the form of John Harden’s Creston Hills. Platted in 1928, Creston Hills was an example of a master-planned suburb that included a shopping center, park and school. Harden’s aggressive marketing combined the opportunistic appeal of single-family homeownership with the stability of good city planning. The buildout of Creston Hills was stalled somewhat by the Depression, but the housing that was built captured the essence of the 1920s real estate boom in the city.



Image 1G: Creston Hills promotional material

JOHN JAMES HARDEN

John Harden was born in Ionia County Michigan in 1883. He came to Oklahoma City just after statehood and began subdividing and selling land across the state. In the 1920s he added development to subdivision by building speculative houses, mostly in the Tudor Revival style. Harden did not limit himself to residential real estate but also built cemeteries, hotels and public markets.



Image 1G: Panorama view of Wescott Court, 1306 NE 20th Street



Additions - 1929

1. OAK PARK
2. PARK PLACE
3. JORDAN PLACE
4. ROSS HEIGHTS
5. PROSPECT HEIGHTS
6. EAST HIGHLAND
7. BATH HIGHLAND
8. GAST HEIGHTS
9. BANCROFT
10. EASTVIEW
11. EDMONT
12. WHITE ORCHARD
13. AUGUSTA HEIGHTS
14. CRESTON HILLS
15. SUCCESS

Image 1H: Sears precut home No. 3308 (Hillsboro model), 1931 catalogue

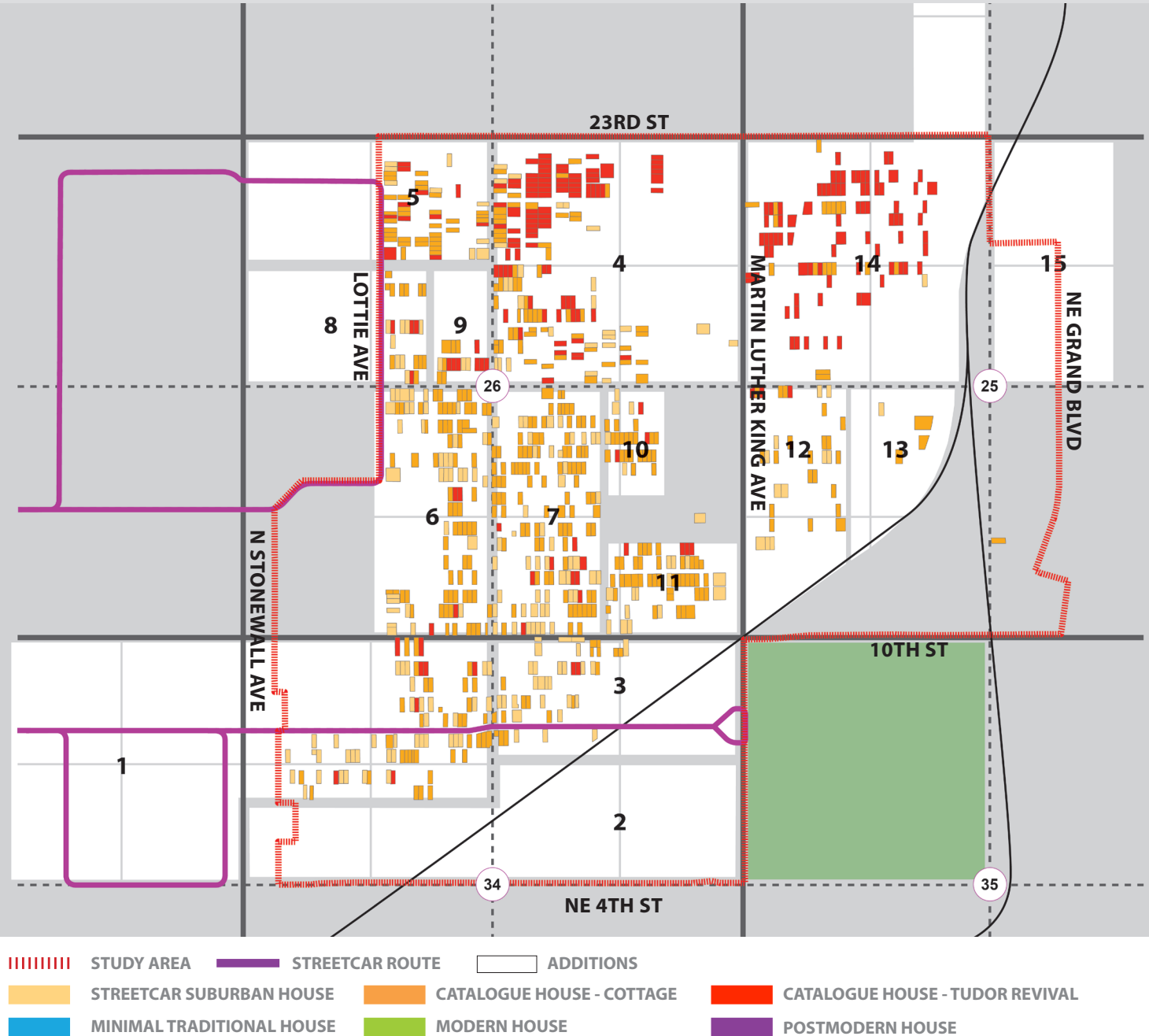

FIGURE 1.1.2



1.1 Neighborhood Evolution

1.1.3 Depression & War

Oklahoma City's oil industry provided some measure of insulation against the Great Depression, but by 1932 housing construction had stalled across the nation. In response, Franklin Roosevelt created the Federal Housing Administration in 1934 to provide mortgage guarantees for 30-year loans, encouraging home construction and reinforcing local banks. However, FHA guarantees came with strings attached. Standards for both neighborhood design and residential architecture produced repetitive products; and while some variations could be used to reflect local building traditions, the influence of the construction industry and restrictions against investing in poor or crowded neighborhoods accelerated the rise of the suburban tract home. Shown in blue in Figure 1.1.3, this house category was built in great quantities both before and after World War II.

Similar to the influence of the state government complex, Northeast Oklahoma City was heavily affected by the construction of Tinker Air Force Base in 1941. Most of the housing demand from war production was satisfied by the private development of Midwest City; but the completion of Creston Hills and the platting and development of Edwards Heights and Carverdale provided housing for workers, especially African-Americans, who wanted a location closer to downtown. Even early garden-style apartments were built in Culbertson's East Highland. Moreover, while streetcar and bus lines help stimulate infill in Ross Heights, increased car ownership and emerging suburban retail along NE 23rd contributed to the attractiveness of the area.

WALTER J. EDWARDS

Walter Edwards was a living example of the American spirit that was common in the West. Born in rural Mississippi, he came to Oklahoma City in 1915 with only a rudimentary education. From working in junkyard to eventually owning several businesses, Edwards is most remembered for breaking down racial barriers by developing Hassman and Edwards Heights for African-Americans during segregation.



Image 11: Panorama view of 1306 NE 20th Street (right); 1940s duplex housing, Midwest City (left)



Additions - 1935

1. OAK PARK
2. PARK PLACE
3. JORDAN PLACE
4. ROSS HEIGHTS
5. PROSPECT HEIGHTS
6. EAST HIGHLAND
7. BATH HIGHLAND
8. GAST HEIGHTS
9. BANCROFT
10. EASTVIEW
11. EDGEMONT
12. WHITE ORCHARD
13. AUGUSTA HEIGHTS
14. CRESTON HILLS
15. EDWARDS HEIGHTS
16. CARVERDALE



SUBDIVISIONS PLANNED
as NEIGHBORHOODS are

- more profitable to developers
- better security for investors
- more desirable to home owners

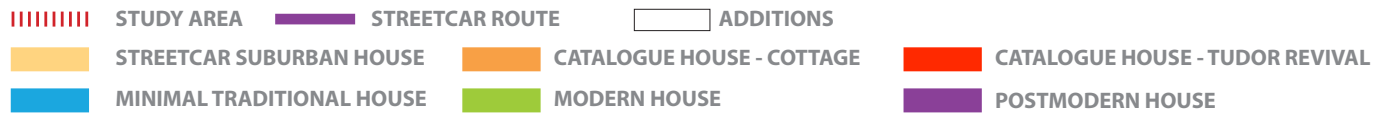

Image 1J: Excerpt from "Planning Profitable Neighborhoods", Federal Housing Administration Technical Bulletin No. 7, 1938

FIGURE 1.1.3



1.1 Neighborhood Evolution

1.1.4 Postwar to Postmodern

As happened in most American cities, a booming economy coupled with low-interest mortgages and automobile ownership created strong demand for suburban development; and consequently many older urban neighborhoods suffered from depopulation and a lack of new investment. Coupled with demolition from urban renewal and road projects, neighborhoods like JFK and Culbertson East Highland were hit hard both physically and economically. Yet there were still pockets of new construction that improved undeveloped portions of early subdivisions, and federally-subsidized programs that helped replace deteriorating older homes with new ranch-style models. Even noteworthy Midcentury Modern architecture like the house shown below can be found.

The largest concentration of new housing development during this period is located in the JFK neighborhood north of NE 4th Street. While some of this has been built fairly recently, there are plentiful examples of 1980s ranch houses still adhering to the basic form developed in the 1950s – albeit with a projecting one- or two-car garage. Other noteworthy collections of classic ranches can be found along North Nebraska Avenue and Hardin Drive. As tastes in suburban residential design changed in the 1990s, new construction in the Northeast neighborhoods followed suit. Today, one can find classic postwar housing based on the evolution of the Depression-era small house, through the “rambling ranches” of the 1960s and 1970s, and on up to today’s Postmodern designs that look back at earlier period revivals.



Image 1K: Typical 1970s scattered-site ranch house

SCATTERED-SITE HOUSING

The 1960s and early 70s were periods of national social unrest and reaction against destructive government programs such as urban renewal and public housing. HUD’s scattered-site program offered an alternative model through small-scale dispersed one- and two-family homes designed to blend in with market-rate suburban housing. In older neighborhoods however these standardized designs often clashed with older homes, branding them as “low-rent” despite good intentions.



Image 1L: Panorama view of 1305 NE 8th Street



Neighborhood Associations

1. HARRISON-WALNUT
2. JOHN F. KENNEDY
3. CULBERTSON EAST HIGHLAND
4. ROSS HEIGHTS
5. PITTS PARK
6. MARTIN LUTHER KING
7. CRESTON HILLS NORTH
8. CRESTON HILLS SOUTH / WHITE ORCHARD
9. CARVERDALE
10. EDWARDS COMMUNITY CLUB

Image 1M: Street network prior to construction of J. W. Simmons Boulevard, 1964 view

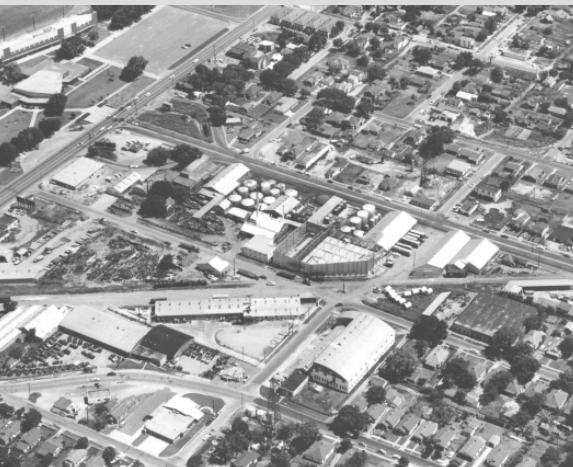
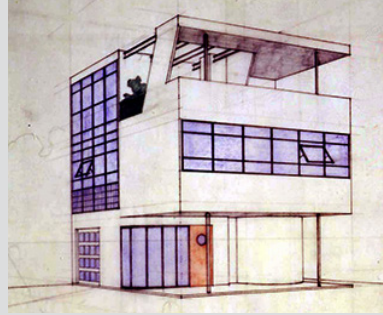

FIGURE 1.1.4



1.1 Neighborhood Evolution



1.1.5 Recent Developments

Most of the housing that has been built in the last ten years in the neighborhoods of JFK and Culbertson East Highland has been varying versions of current suburban designs, either as evolutionary ranch houses or houses built on ranch plans with traces of French or English historicist exterior forms and details. While clearly reflecting current suburban development trends, some of these houses can also claim a formal connection back to the Tudor Revival / English Cottage models built in Ross Heights and Creston Hills. The use of brick cladding, large front gables and steep roof pitches are similar to the style devices used in homes from the 1920s and 1930s.

A second trend that is only beginning to be felt in Northeast Oklahoma City is the custom-designed Modernist house that is intentionally different from more traditional styles. While these designs are highly idiosyncratic, they generally use classic Modern materials like steel, glass and concrete; planar surfaces and flat roofs; and an absence of decorative ornamentation. These houses seem at odds with the history of the area, but in fact there is a direct connection to an older experiment in Modern architecture.

In 1934 John J. Harden had a series of written exchanges with Foster Gunnison of Houses Incorporated in New York City. Harden had seen a model of the prefabricated "Motohome" in New York and was impressed enough with the design to begin a dialogue on supplying them for the unbuilt portion of Creston Hills. The deal was never completed, but it is intriguing to think that prefabricated International Style houses might have graced the streets of Creston Hills. Steel houses were challenged by labor unions and never achieved commercial success. The few surviving examples are now being restored as examples of housing innovation and design excellence.



Images 1N: Winslow Ames House, New London, CT (top); Creston Hills cottage (bottom)



Image 1P: Elevation drawing of White's Motohome Colony





Images 10: Recent residential construction in the neighborhood

THE MOTOHOME

This innovative housing type was one of the more successful models to emerge out of 1930s experiments in mass production. Centered on a modular “motounit” that contained mechanical systems, the Motohome was marketed heavily but never achieved commercial success. The Winslow Ames house (Image 1N - top) is a rare survivor.

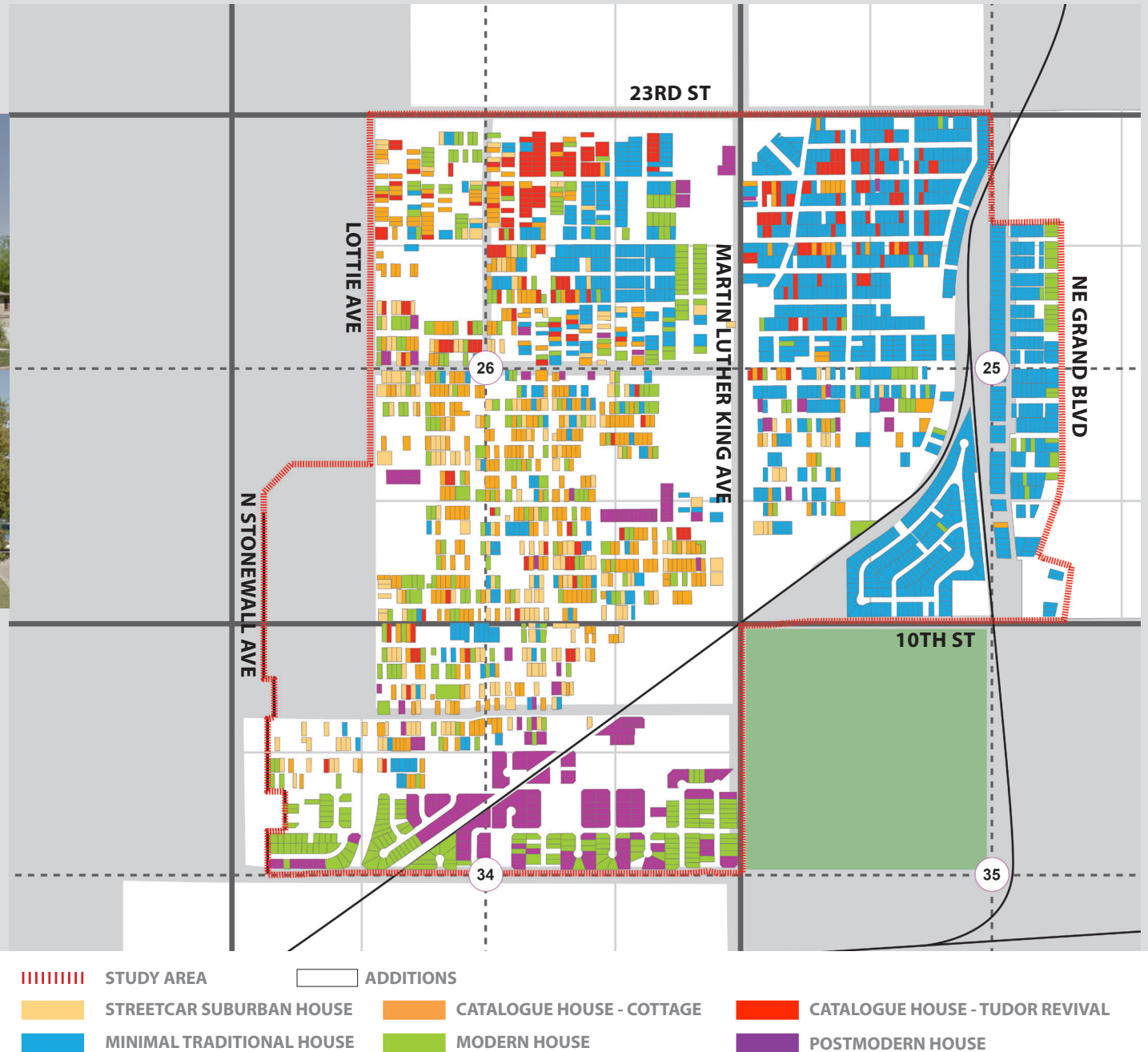

FIGURE 1.1.5



1.2 Existing Architectural Categories

1.2.1 The Streetcar Suburban House

Almost every large American city has at least one neighborhood that could be called classic; one with wide sidewalks and big trees, front porches and bright colors. Chances are this neighborhood is close to downtown, yet far enough away to have its own park, its own school and maybe its own shops. It is the model of a walkable urban place that is well-connected and diverse. But when it was built it was considered a suburb, intentionally distant from the urban core and its congestion. It was built for the middle class - and the housing reflected middle class aspirations.

The streetcar lines discussed in the opening section had an effect on development of early land subdivisions or urban “additions” in Northeast OKC, but not in the same way as other parts of the city. While neighborhoods like Heritage Hills, Mesta Park and Jefferson Park were comprehensively developed by businessmen like Anton Classen and Gilbert A. Nichols, the homes that were built along the Fairgrounds and Capitol streetcar lines were largely the product of small builders using architectural plan books sourced from publications like *House Beautiful* magazine. The most elaborate homes were generally closest to the streetcar lines, which increased their sales value for the builders whose limited production depended on a high return.

This first set of categories is drawn from the remaining streetcar suburban houses that date from 1910 through 1920. They are dominated by one-story Bungalow models though some two-story examples are present. There are also limited instances of two-family (duplex) houses in side-by-side or flat-over-flat versions. Several large, ornate homes are located at intersections; but in general most streetcar suburban homes in Northeast have architectural features that are evocative of their pattern book origins.

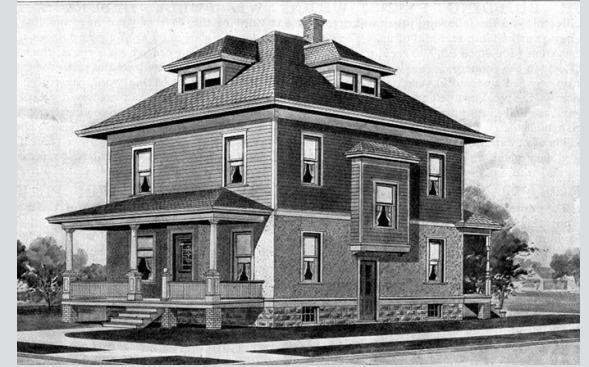

Image 1Q: A sampling of designs from John Henry Newson's "Homes of Character" plan book, 1913



- ||||||| STUDY AREA
- █ EXISTING PARK
- █ STREETCAR SUBURBAN HOUSE

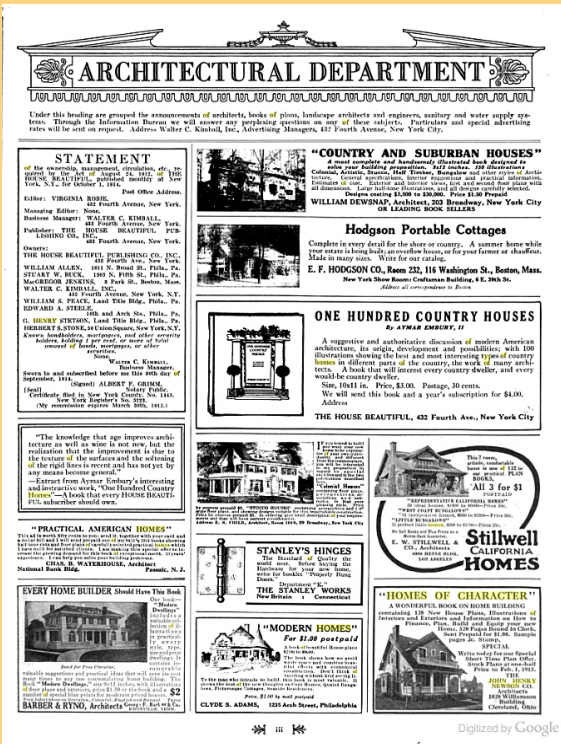
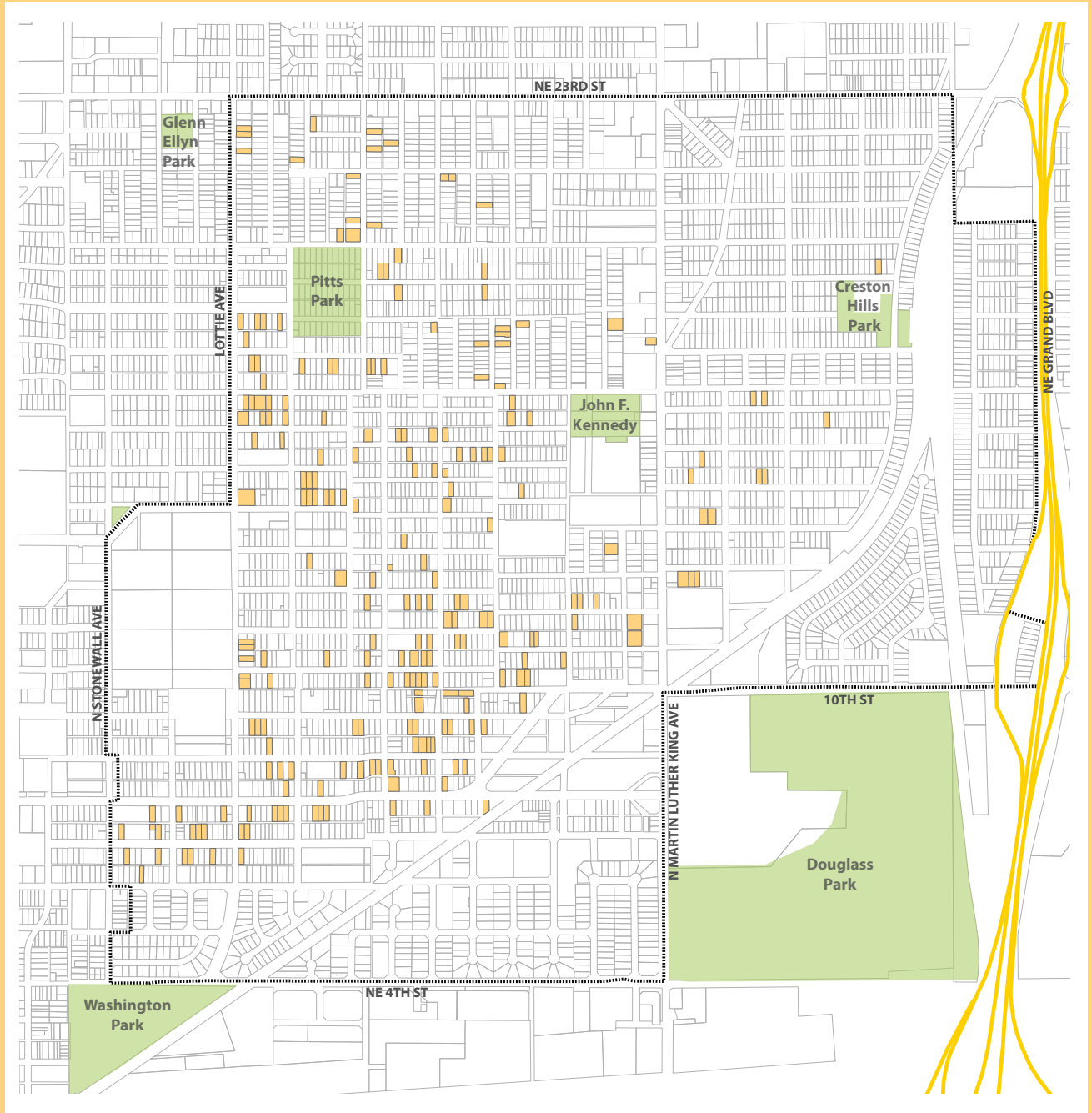

Image 1R: Excerpt from House Beautiful magazine, 1910

FIGURE 1.2.1

1.2 Existing Architectural Categories

1.2.1 The Streetcar Suburban House: BUNGALOW

The Bungalow is the quintessential streetcar suburban house because of its association with the Arts & Crafts movement, which dominated trends in residential architecture at the time streetcar systems were emerging; and because it contained “modern” features like an open plan, built-in furniture and a functional kitchen which coincided with the technological innovation of the streetcar. Bungalow construction was widespread after World War I and has stylistic differences depending on the region of the U.S. where it is found. At its simplest, it is a basic rectangular box with an all-encompassing roof and substantial front porch.

Distinguishing features:

- Single story
- Full-coverage roof
- Full-width porch
- Strong Arts & Crafts styling



Side- and Front-Gable Variants



Front-Gable Variant





Hipped roof dormer

4/12 to 6/12 roof slope

Hipped roof

Substantial Piers

1 story

Entry door with sidelight
two-bay façade division

Double hung windows
Vertical proportions

Porch: Full width of the house

1.2 Existing Architectural Categories

1.2.1 The Streetcar Suburban House: AMERICAN FOURSQUARE

The Foursquare is another “modern” house that was developed in the 1890s as a reaction to the perceived fussiness of Victorian designs. The name derives from the generally square plan, containing one major room in each corner with connecting doors which minimized the need for hallways. Foursquares were advertised as the most efficient way to provide the largest amount of interior space in the smallest footprint, which made them ideal houses for small urban lots. The simplicity of the foursquare form also provided flexibility to support many different architectural styles including Prairie (1), Italianate (2) and Arts & Crafts (3).

Distinguishing features:

- Two-story cubed mass
- Hipped roof
- Full-width porch
- Hipped bays (if present)
- Optional attic living space



Varied Styles, Basic Form





Hipped roof dormer

Hipped roof

Double hung windows

Two-story cubed mass

Full width porch



1.2 Existing Architectural Categories

1.2.1 The Streetcar Suburban House: NATIONAL

The National House is a catch-all term used to describe simple vernacular (or folk) dwellings built across the country from dimensional lumber transported by rail. In urban locations they frequently take the form of a simple gable front mass - a holdover from the more ornate Greek Revival style - and a projecting porch. The National house is quite similar in plan to a bungalow, except with two stories instead of one. Like the bungalow it was commonly built with Arts & Crafts elements but could also feature limited Greek Revival details such as eave returns and corner boards.

Distinguishing features:

- Two-story long mass
- Gable-end roof
- Full-width porch
- Gabled bays (if present)
- Optional attic living space

Greek Revival Example



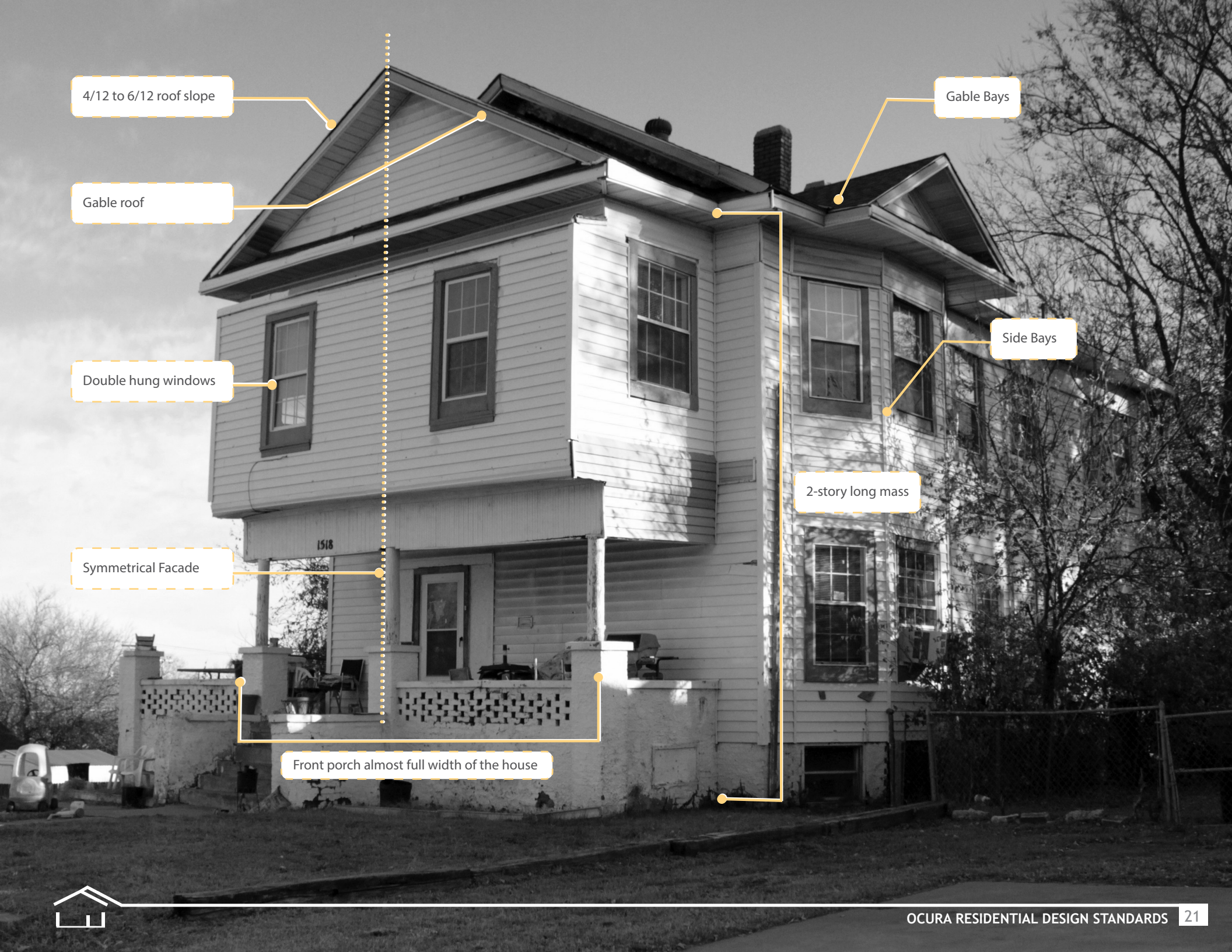

4/12 to 6/12 roof slope

Gable Bays

Gable roof

Side Bays

Double hung windows

2-story long mass

Symmetrical Facade

Front porch almost full width of the house



1.2 Existing Architectural Categories

1.2.1 The Streetcar Suburban House: TWO-FAMILY DWELLINGS

Some of the houses associated with streetcar lines take advantage of slightly wider lots to include two dwelling units within one structure. The most common example in Northeast OKC is the side-by-side duplex that is patterned after the English “semi-detached” suburban house which was built by the thousands around major cities like London and Birmingham. The duplex in America is associated with Eastern urban centers like Boston and Savannah more than it is with the West, so the appearance of duplex housing in Oklahoma City may have originated with the desire to import English architectural styles through plan books. Another form of the two-family house in Northeast neighborhoods is the “over-and-under” or small apartment building.

Distinguishing features:

- One- or two-story versions
- Usually symmetrical front façade

Semi-Detached, Northhampton, UK



Side-By-Side House



Over-And-Under House



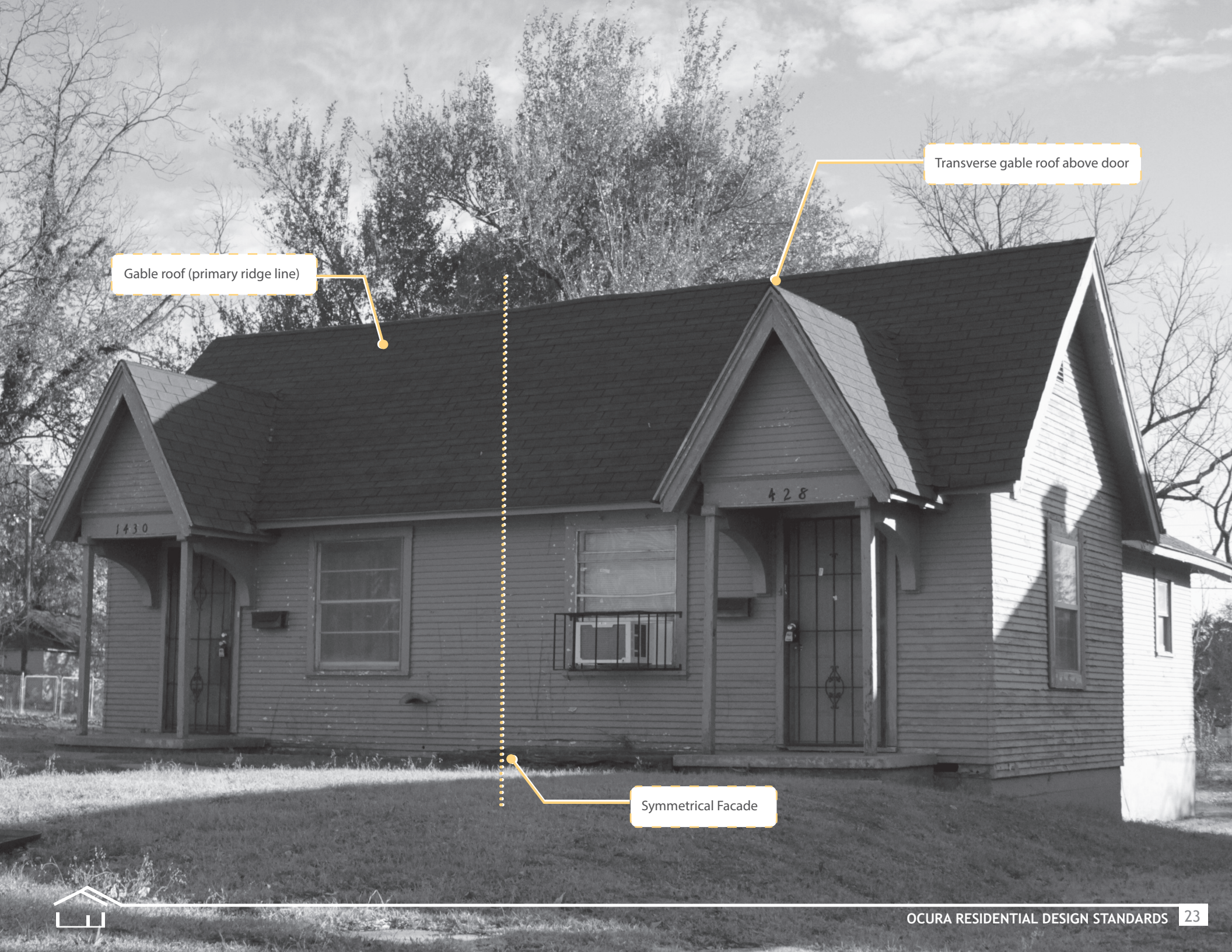

Gable roof (primary ridge line)

Transverse gable roof above door

Symmetrical Facade



1.2 Existing Architectural Categories

1.2.2 The Catalogue House

The 1920s marked the beginning of large-scale house production in two ways: with the emergence of real estate developers like John J. Harden that subdivided and built neighborhoods like Crestwood and Creston Hills; and with the growth in popularity of mail-order or catalogue housing like Honor Bilt (Sears Roebuck), Wardway Homes (Montgomery Ward), Harris Homes (Harris Brothers), Pacific, Aladdin, and Gordon Van Tine. Oklahoma City was well-connected to Midwest and West Coast manufacturing centers by four railroads, and therefore a ready market for either complete house kits or plans sourced from company catalogues.

With the completion of the Oklahoma State Capitol in 1917, University Hospital in 1919, and the oil boom in 1928, Oklahoma City's Northeast neighborhoods grew rapidly. Exclusive residential areas like Lincoln Terrace were almost completely built of period revival architecture, and especially Tudor Revival which had grown in popularity among the East Coast gentry for its association with English heritage. More modest houses continued the earlier trend of Craftsman / Arts & Crafts styling, but also introduced a smaller version of the Tudor Revival known as the English Cottage. These were built predominately in the Lincoln Terrace East neighborhood, mostly of brick but some of local stone, stucco, or even wood siding.

This second grouping of houses reflect the smaller footprints that were associated with modest cottages for state government and hospital employees, as well as downtown workers. It is unknown whether these houses were the products of mail-order companies; but for all intents and purposes they could be considered reflections of them because they display the architectural trends contained in their catalogues.

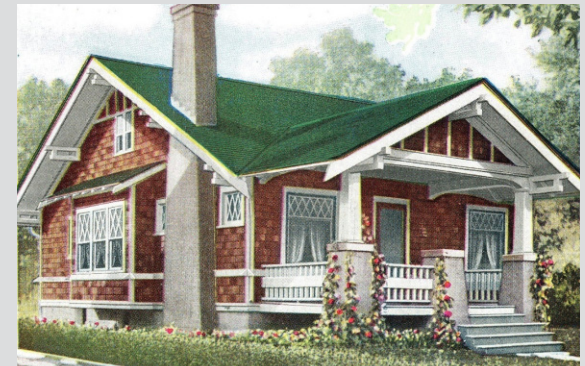
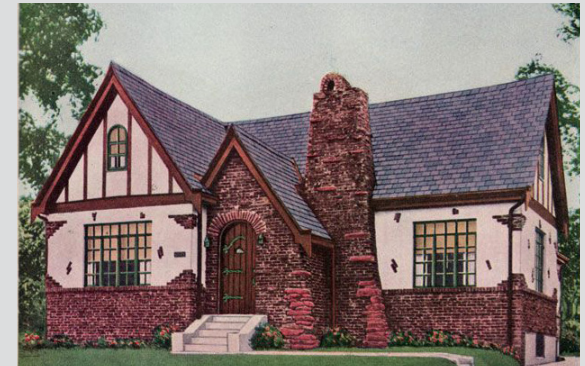

Images 1S: Precut house designs from a variety of manufacturers including Gordon Van Tine (top and center bottom), Sears (center top), and Aladdin (bottom)



- ||||||| STUDY AREA
- EXISTING PARK
- CATALOGUE HOUSE - CRAFTSMAN COTTAGE
- CATALOGUE HOUSE - TUDOR REVIVAL



Image 1T: Sears Precut Home Catalogue, 1920s

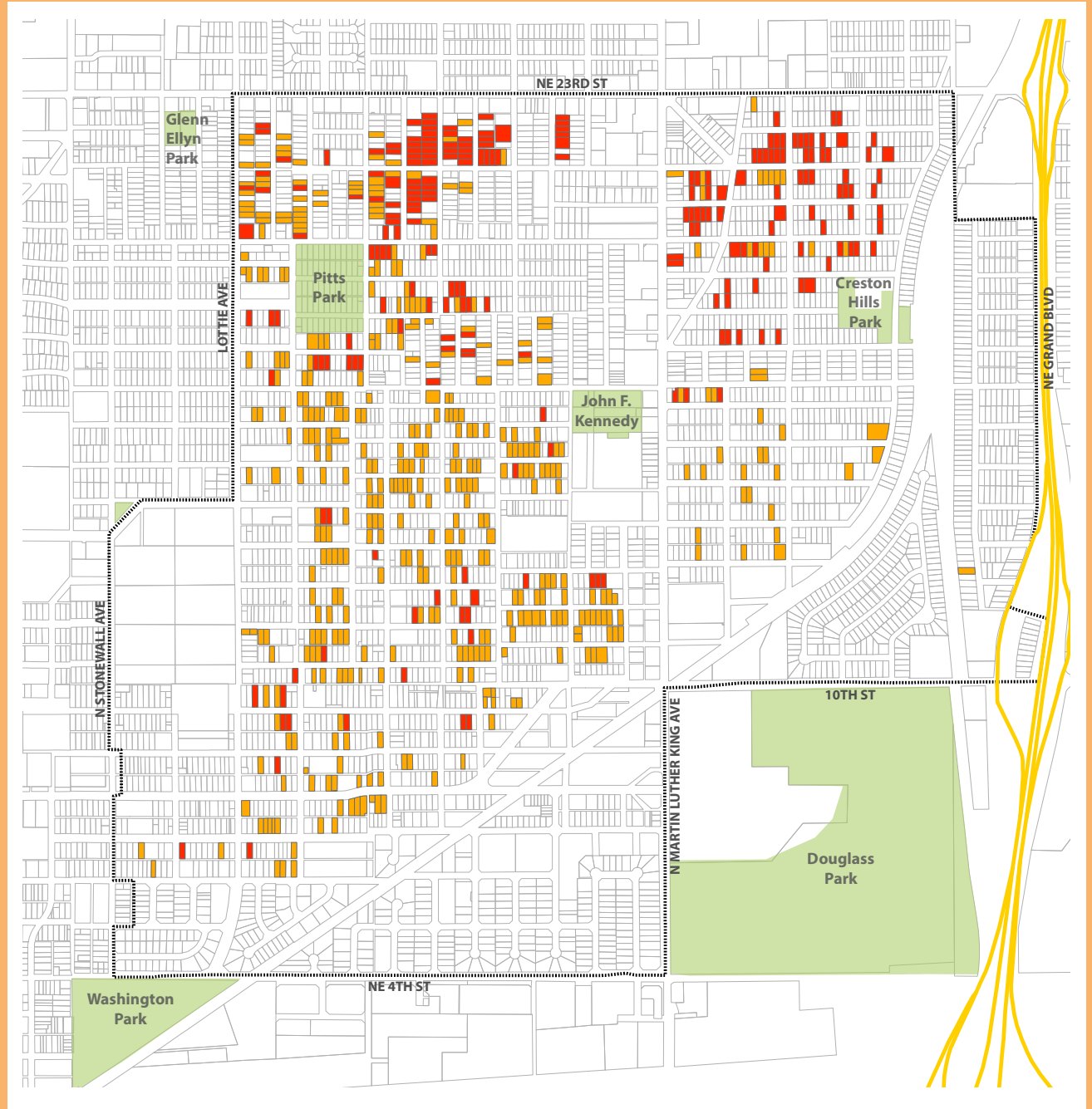

FIGURE 1.2.2



1.2 Existing Architectural Categories

1.2.2 The Catalogue House: CRAFTSMAN COTTAGE

While the Craftsman Cottage is often called a bungalow in 1920s publications, this guide makes a distinction between the larger, older form built during street-car development and this later, more compact version. There are at least two variants dominating the area – a “stepped gable” version where a smaller gabled porch is positioned to the side of a large gable-front mass; and a “cross-gable” version with a hipped or gabled front porch and the primary ridge line running parallel to the lot frontage. Despite the plan variations, Craftsman Cottages are united in their restrained details which include exposed rafter tails, brick piers with tapered columns, ganged windows, and simple eave brackets.

Distinguishing features:

- Restrained Arts & Crafts styling
- Main ridge line runs perpendicular (stepped-gable) or parallel (cross-gable) to front façade
- Small front porch either offset (usually stepped-gable) or centered (usually cross-gable)



Stepped-Gable Variant



Stepped-Gable Variant



Cross-Gable Variant



Cross-Gable Variant



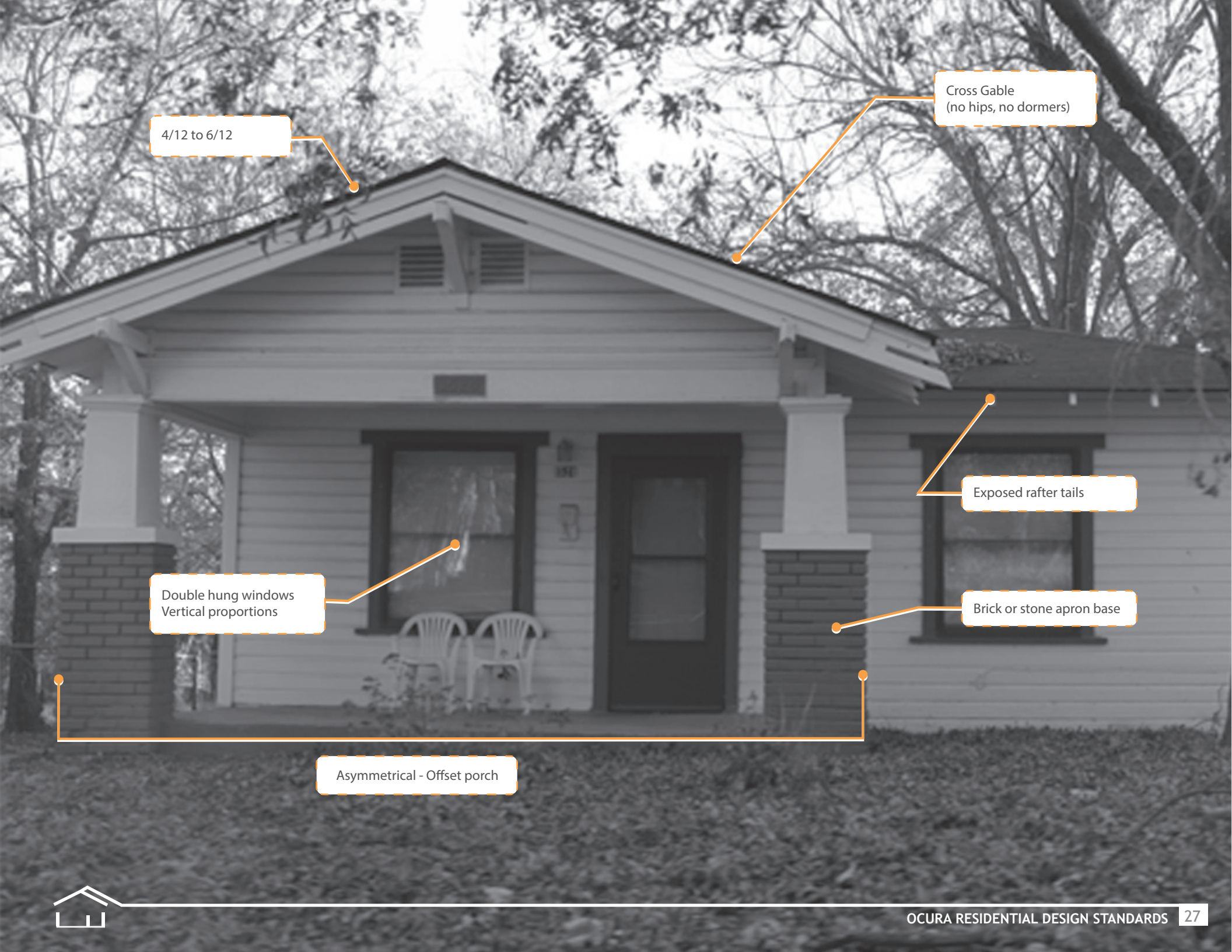

4/12 to 6/12

Cross Gable
(no hips, no dormers)

Exposed rafter tails

Double hung windows
Vertical proportions

Brick or stone apron base

Asymmetrical - Offset porch



1.2 Existing Architectural Categories

1.2.2 The Catalogue House: TUDOR REVIVAL

The widespread popularity of Tudor Revival houses in Oklahoma City's exclusive neighborhoods contributed to the rise of a smaller version sourced from builders catalogues. While the English origins remain the same, the subtype was not based on Tudor manors but on the quintessentially English cottage of the Cotswolds as well as Arts & Crafts houses by Charles Voysey and Hugh Baillie Scott. Also known as the Storybook Style, these houses often combined a sense of solidarity with English culture and the allure of Hollywood that was emerging with the rise of motion pictures in the 1920s.

Distinguishing features:

- Usually in brick or stone
- Primary ridge line parallel to front façade
- Large gabled bay at front, sometimes asymmetrical
- Exposed chimney stack with decorative details
- Decorative half-timbering on some models

C. F. A. Voysey, Moorcrag



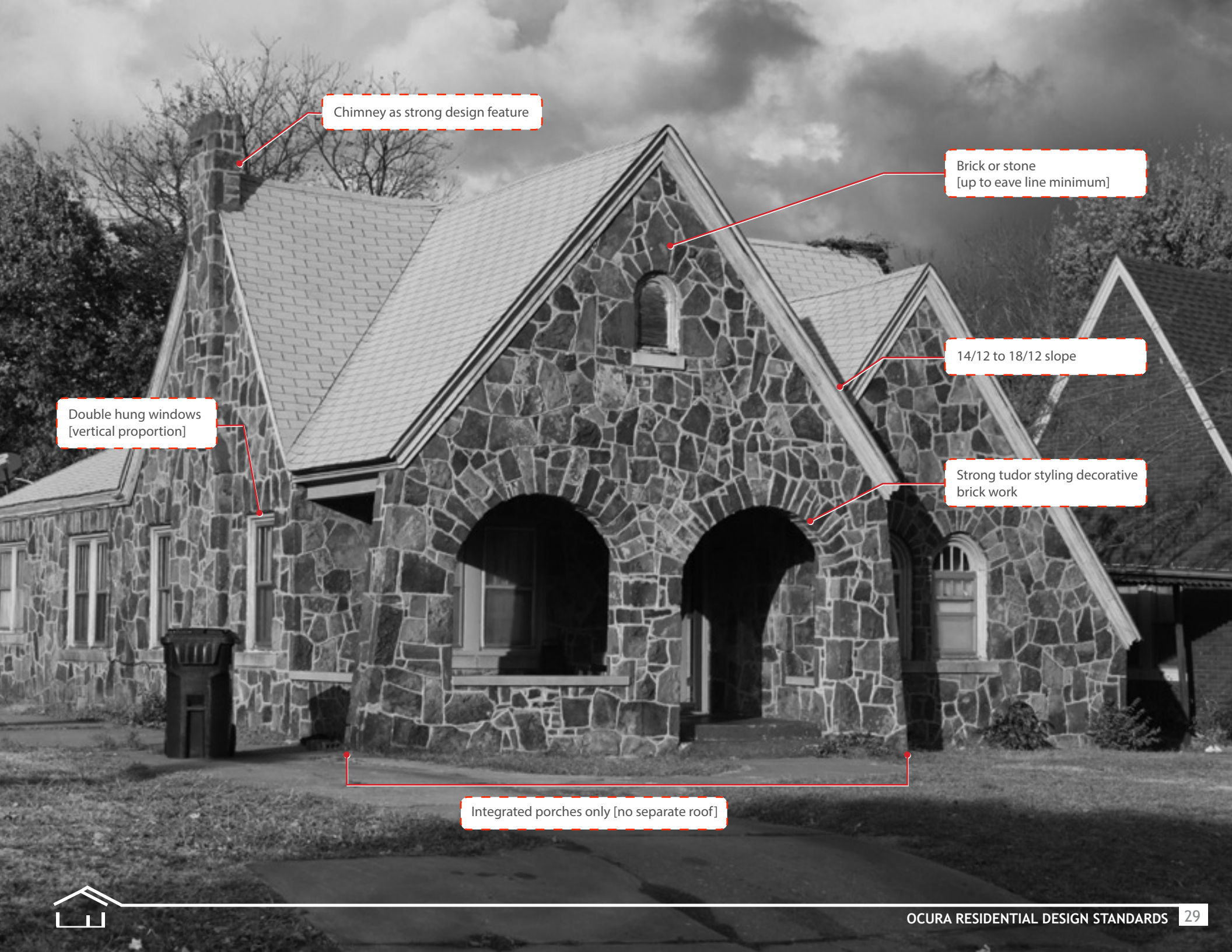

Chimney as strong design feature

Brick or stone
[up to eave line minimum]

14/12 to 18/12 slope

Double hung windows
[vertical proportion]

Strong tudor styling decorative
brick work

Integrated porches only [no separate roof]



1.2 Existing Architectural Categories

1.2.3 The Minimal Traditional House

Also known as the Minimal Traditional, the Cape Cod, or the FHA house, the small home that emerged during the Great Depression was in many ways a quiet revolution in American housing design and production. Stripped of most ornamentation and compact but efficient in plan, these houses were the result of a 1931 National Housing Conference and the subsequent 1934 National Housing Act which created the Federal Housing Administration. Advocating for a national housing policy was also a logical next step for the real estate industry after helping create enabling legislation for zoning and city planning; and from this point on residential development became big business.

FHA's mortgage guarantees were only one reason for the burst of house construction in Creston Hills and nearby neighborhoods in the 1930s and 1940s. The opening of the Midwest Air Depot (Tinker AFB) in 1942 and the adjacent Douglas Aircraft assembly plant in 1943 provided an influx of jobs which created demand for affordable housing. While Midwest City was basically built from scratch in response, the employment level was so great during and after World War II that most of the remaining land along North Eastern (Martin Luther King) Avenue was developed with this category.

The basic Minimal Traditional House is a simple two-bay vernacular box with a living room and kitchen at the front and two bedrooms at the rear. The wood frame construction, often prefabricated, allowed a wide variety of exterior materials including lap siding, wide cedar shingles, face brick, or local stone. Because the emergence of the category overlapped with the time period of the English Cottage, many were built with similar exterior forms and design features though plans remained faithful to the two-bay template.

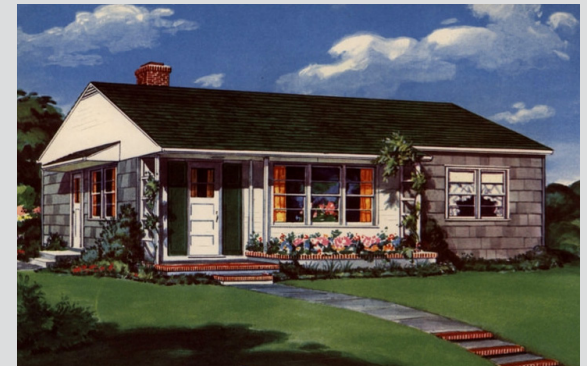
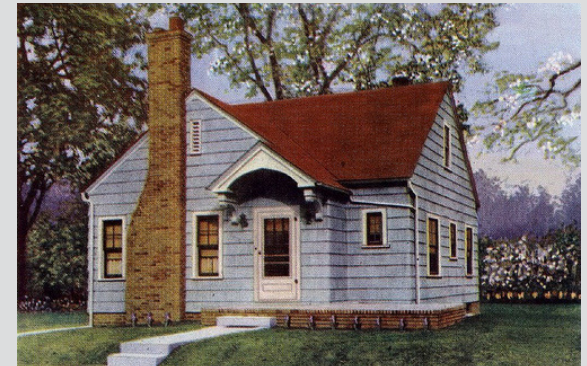
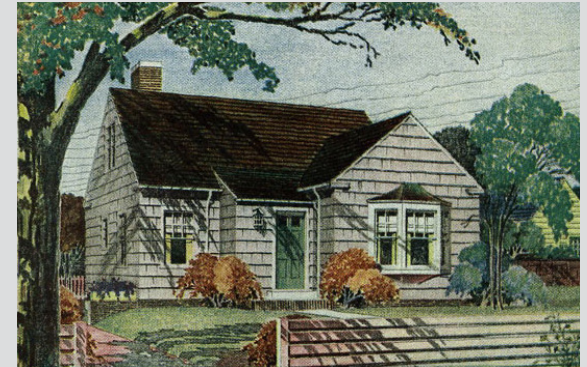
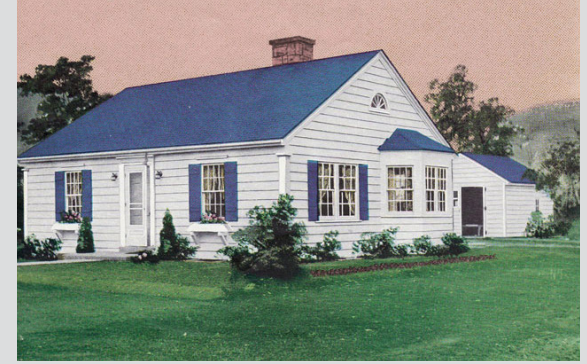

Images 1U: Major manufacturers adjusted their product lines to reflect the influence of FHA standards and a widespread preference for the “Cape Cod” aesthetic



- ||||||| STUDY AREA
- EXISTING PARK
- MINIMAL TRADITIONAL HOUSE

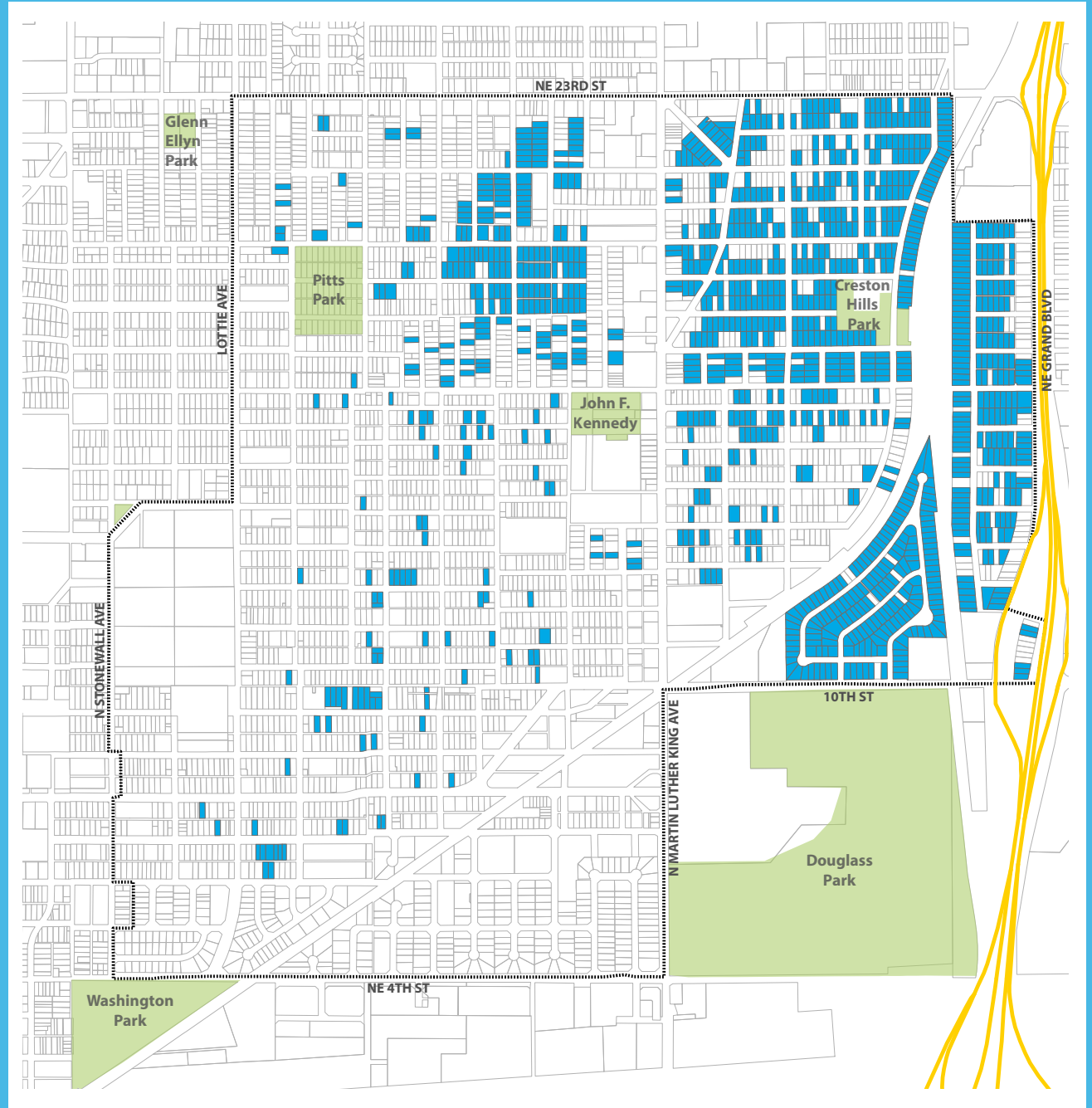

Image 1V: Creston Hills marketing material

FIGURE 1.2.3



1.2 Existing Architectural Categories

1.2.3 The Minimal Traditional House

The Minimal Traditional House was intended to encourage homeownership through low purchase price and a thirty-year FHA-backed mortgage. Mass production techniques helped reduce construction costs; and FHA publications codified the design formulas which made the housing a safe investment. Adaptability was a hallmark of this category, and the basic two room by two room model was often customized by the addition of a side porch or room, a habitable attic, or a small garage as well as more durable masonry cladding. Moreover, as car ownership became more prevalent in the 1940s, the side-garage variant became so popular that it laid the groundwork for the emergence 1950s ranch house.

Distinguishing features:

- Rectangular plan, usually with centered door
- Shallow transverse gable roof
- Sometimes has small projecting bays at ends

Royal Barry Wills, Cape Cod Cottage



Enhanced Variant



Early Ranch Variant





Small traverse gable
No hips

Side gable - primary ridge line

4/12 to 6/12 slope
[same slope in all roofs]

Double hung windows
[vertical proportion]

One story

Lap siding

Basic Arts & Crafts styling



1.2 Existing Architectural Categories

1.2.4 The Modern House

As family incomes increased in the 1950s and suburban development picked up speed, housing styles changed to reflect a more relaxed and informal way of life. The West, in particular, was fertile ground for architects pushing the boundaries of what defined a house. In Los Angeles, the Case Study Houses became the model for cutting-edge residential design that is felt in Oklahoma City even today; while the modern ranch house evolved from the Bay Area work of William Wurster. Oklahoma was also receptive to the work of Frank Lloyd Wright whose Usonian houses were the inspiration for several residential projects in Oklahoma City.

Modern houses (defined as those built in 1950s through the 1970s) are scattered throughout the Northeast neighborhoods with mixed success. In some cases, sensitively-designed early ranch houses were inserted into infill lots in older areas, or built in small clusters like those fronting North Nebraska Avenue. In other cases, stock designs with protruding garages or blank front facades occupy areas where older houses were cleared during urban renewal efforts in the 1970s and 80s. There is also at least one example of a high-style Modern house that reflects the architectural trends of the 1940s.

It goes without saying that much of the design quality of the Modern housing stock is dependent on age and context. Older ranch houses tend to contain more one-off designs and unique features, while later versions resemble tract housing that replicates one or two different models.

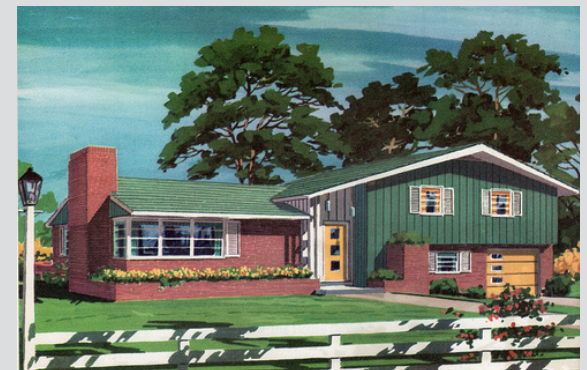
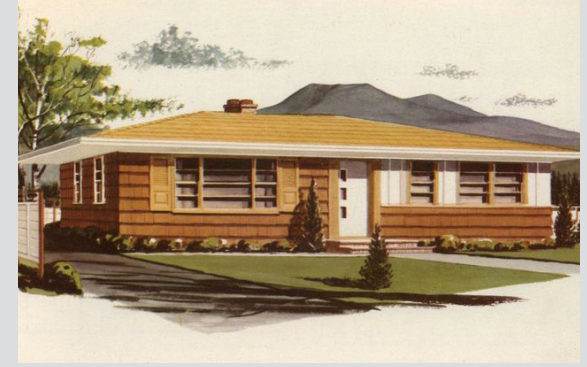

Images 1W: By the 1960s the pre-cut house was eclipsed by models built by large-scale developers. Only three companies remained in business - Aladdin, Liberty and Sterling.



- ||||||| STUDY AREA
- EXISTING PARK
- MODERN HOUSE

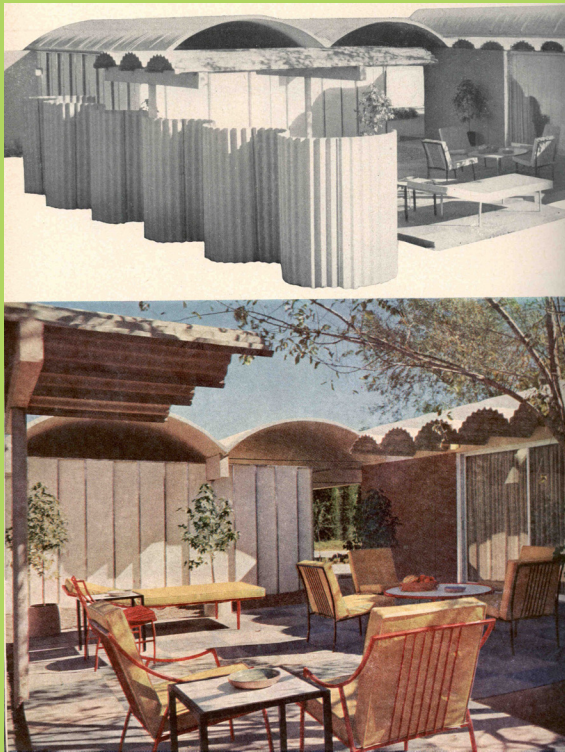

Image 1X: Coley House from the 1959 Parade of Homes

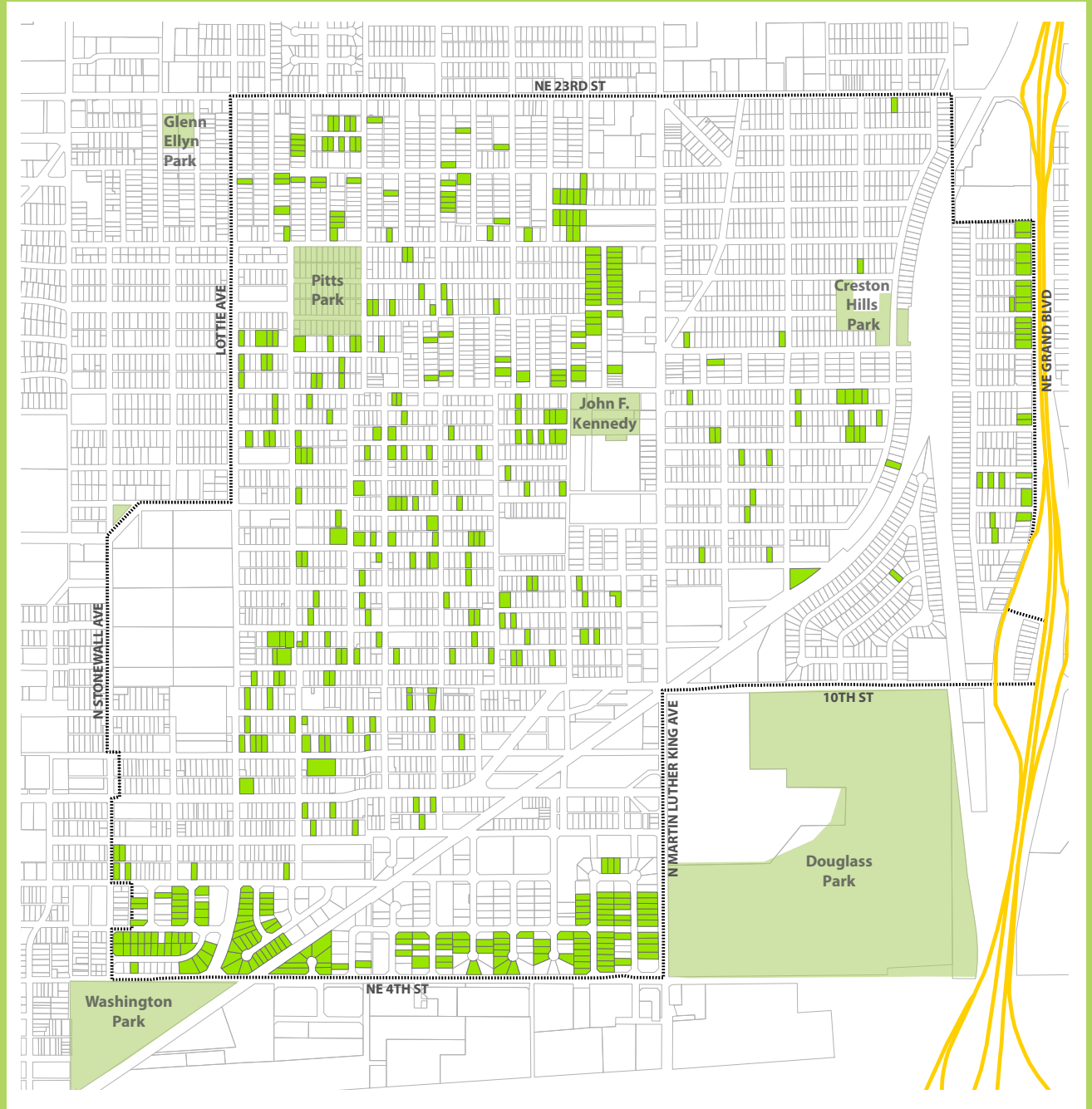

FIGURE 1.2.4



1.2 Existing Architectural Categories

1.2.4 The Modern House: RANCHES

Most of the ranch-style houses in the Northeast neighborhoods are products of standardization and have little design enrichment beyond varying exterior brick textures and colors. More elaborate renditions tend to have details like long, horizontal planter boxes; concrete masonry or brick screen walls; cantilevered box bays; and aluminum or steel sash windows. In all cases a one- or two-car garage is usually located adjacent to a recessed entry featuring a large window into the main living space.

Common Ranch House Elements:

- Rectangular or L-shape floor plan
- Primary ridge line parallel to front façade
- Shallow hipped or gable roof
- Front facing and protruding garage
- Minimal detailing/ornamentation

50's-60's Ranch House Distinguishing Features:

- Fixed and/or casement windows
- Garage only partially extended beyond front facade
- Very broad eaves
- Tubular metal supports for extra-large overhangs
- Raised entry stoop common

70s-80s ("Tract") Ranch Distinguishing Features:

- Smaller, simpler floor plan
- Garage projects forward significantly
- Some models substitute parking pad for garage
- At-grade entries are common
- Shallower eaves





Hipped roof
[primary ridge line]

Horizontal detailing

Brick façade up to eave line

Double hung windows
Horizontal proportion
Emphasis on horizontal sills

Decorative metal columns



1.2 Existing Architectural Categories

1.2.5 The Postmodern House

The resurgence of interest in urban living has contributed to the revival of many older neighborhoods in Oklahoma City through renovation of historic housing stock and construction of new homes. The new homes in the Study Area can be classified as Postmodern as they include interpretations of various historic stylistic features that are present in the neighborhood. In this document, these Postmodern houses have been further classified as New Eclectic (the ones that relate to historicist aesthetics) and Contemporary (the ones that reinterpret Modernist aesthetics).

In places where there is a lack of existing context, new suburban-style housing has also been developed to attract buyers wanting an urban location with some of the familiarity of the suburbs. While this type of housing could be considered as an evolution of the ranch plan, the free mixing of stylistic elements align it more closely to New Eclectic design.

The area south of the old Missouri-Kansas-Texas rail line and west of MLK Boulevard has the largest concentration of this category of housing. Because of its origins in the suburban ranch, the newer product blends well with houses that were built in the area during the 1980s and 1990s. But unlike tract housing, there is a fair amount of formal diversity among the newer models; and at least one explores the Postmodern genre in an architecturally significant way.

Some New Eclectic houses have also been built on infill lots in older parts of Culbertson's East Highland and Ross Heights. Because of the frequent juxtaposition with older styles and lot proportions, these infill houses do not coexist as comfortably with their surroundings as those further south. For example, while the newest houses have high-quality traditional materials and Arts & Crafts details, the wider lots and ranch layouts work against an accurate rendition of what the historic design elements are intended to provide.

Finally, there are a few examples of a new type of infill housing that is becoming more and more visible throughout Oklahoma City's Northwest. Commonly referred to as Contemporary or "Modernist", this interpretation of International Style architecture owes more to the mid-century work of West Coast architects than it does to the style's European origins.



Images 1Y: A sampling of designs available through Internet sources - March 2015



||||| STUDY AREA
 ■ EXISTING PARK
 ■ POSTMODERN HOUSE

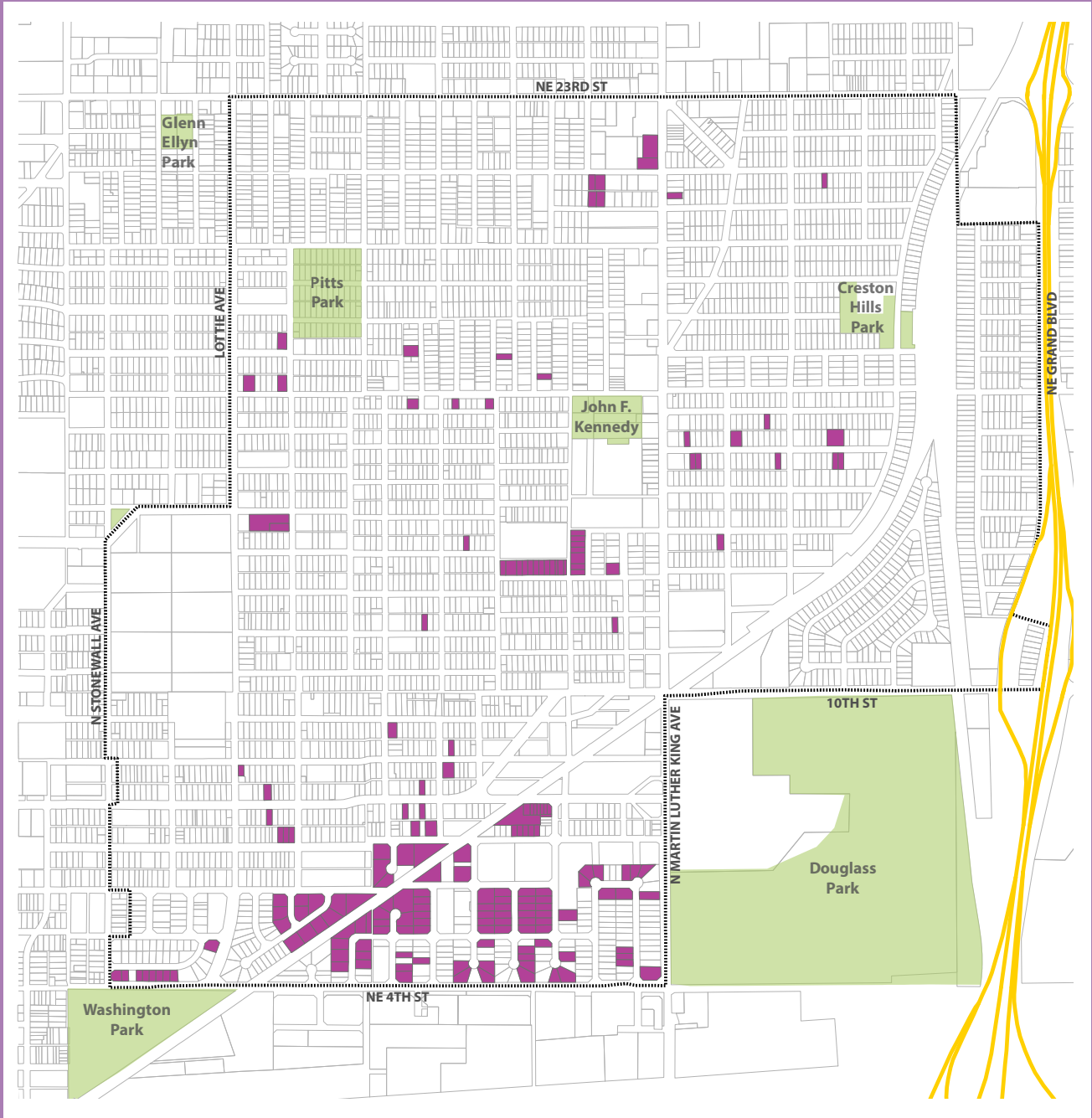

FIGURE 1.2.5



1.2 Existing Architectural Categories

1.2.5 The Postmodern House: THE NEW ECLECTIC

The renewed interest in traditional residential architecture has resulted in an emerging house style that, while sharing the free-flowing plan of a ranch house, uses a wide variety of exterior forms and materials to invoke period styles such as Tudor, Colonial, or Craftsman. These houses tend not to be rigorous academic exercises in revival styles but rather include free interpretations of individual historic design elements. They are gathered under the term “New Eclectic” for their highly varied appearance and idiosyncratic formal composition. In some instances, the combination of ranch house design elements with exaggerated Tudor, Colonial or Craftsman historic details such as gables and eave returns give them an architectural character that defies easy categorization.

Distinguishing features:

- Ranch-style floor plan
- Mix of one and two story
- Brick exterior common
- Varied roof shapes / pitches
- Usually has visible garage
- Divided light windows, sometimes with shutters
- Period details such as dormers and columns



Images 1Z: Examples of new eclectic houses in the neighborhood





Varied roof forms

Two-story foyer

Multiple cross gable roofs

Complex massing

Divided light windows

Brick exterior

Wide front façade



1.2 Existing Architectural Categories

1.2.5 The Postmodern House: THE CONTEMPORARY

There are only two contemporary-style homes located along 8th Street in the Northeast neighborhoods. Built in the same year and probably custom-designed by the same architect, the homes incorporate modern technologies and draw design characteristics from modern architecture such as distinct right angles, clean geometries, larger spans of glass, high ceilings, and open floor plans. Both homes combine of contrasting materials such as wood, cement block, and glass, and celebrate minimalist design with no ornamentation. Unlike other recent homes being built in the neighborhood, these two infill homes have an urban presence and integrate with their context in that their garage is not the prominent front-facade feature and their setbacks align with those of adjacent houses. They, however, challenge such integration through their scale and proportion.

There is a growing demand among millennials and other urban dwellers for contemporary-style homes in major cities across the country, especially in transitional neighborhoods that are in close proximity to their urban centers; the Northeast neighborhoods in Oklahoma City are no different. Though there are currently only two of these homes built in the area, there is precedence for them considering the neighborhood's history and the scattered mid-century examples found throughout.

Distinguishing features:

- “Cubist” massing (Geometrical interlocking shapes)
- Flat or low-pitch roof
- Asymmetrical façade; minimal; no ornamentation
- Use of glass, steel, concrete, wood, and chrome
- High ceilings; floor-to-ceiling windows; open floor plan

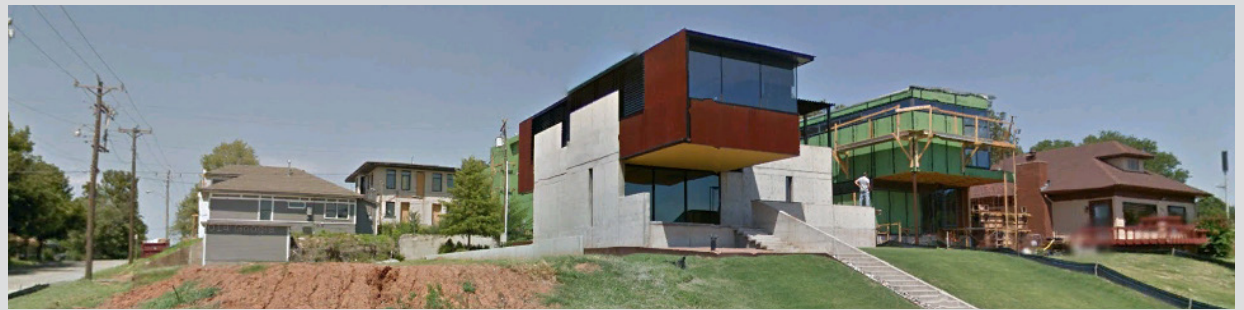

Images 1ZZ: Contemporary houses, Oklahoma City



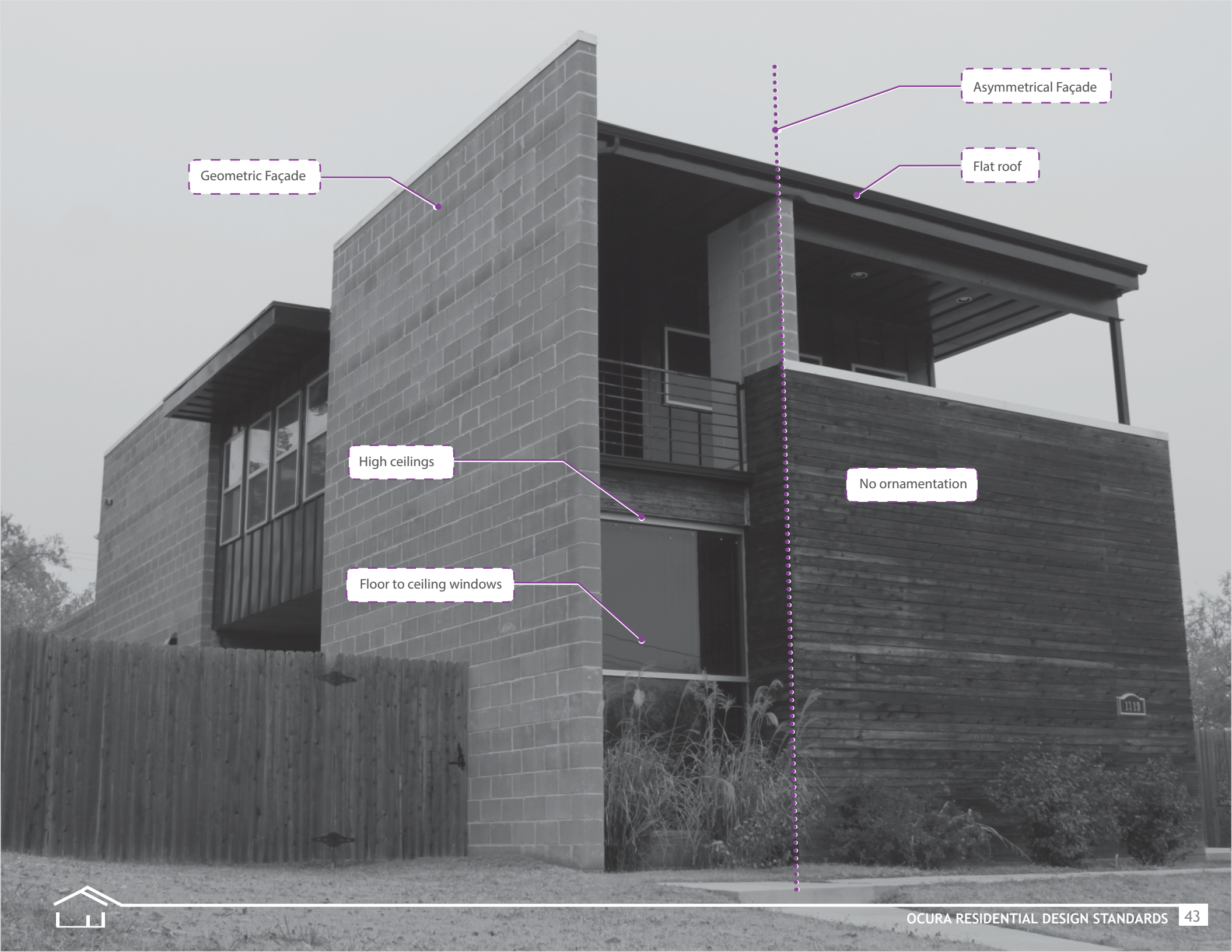

Geometric Façade

Asymmetrical Façade

Flat roof

High ceilings

No ornamentation

Floor to ceiling windows





2.0 Architectural & Site Design Standards

The standards on the pages that follow are intended to illustrate how infill housing can be compatible with the unique and varied historical development patterns of the Study Area. Some standards such as a new house's placement on a lot, the location of garages, the use of fences, the location of sidewalks, etc. are considered to be fundamental and apply to ANY new housing developed, regardless of style or composition.

As illustrated in Chapter 1 of this document, five existing architectural categories with corresponding subcategories were identified in the Study Area. In deference to the varied and valuable historical features found in some of them, **six new distinct architectural categories** are hereby established and further defined as templates for new construction. Not all existing architectural categories were deemed appropriate to become a new architectural category; for example, the New Eclectic House identified in the research is not an approved new category.

These standards are intended to create more consistent and compatible development although flexibility and creativity are encouraged. It should be noted that several existing house categories are not specifically addressed in the standards that follow including Two-Family homes, the American Foursquare and the National. New construction of these categories are possible and could be adapted from some of the six categories but will be handled on a case-by-case basis. Similarly, while not specifically addressed, these standards could be used to inform rehabilitation efforts.

2.1 Site Planning Standards

Note:

Site planning standards apply to all new houses regardless of architectural category

2.1.1 Property and Building Basics

Resubdivision / Lots Widths:

- Use existing lot dimensions where feasible (eg, avoid resubdivision)
- Typical existing lot dimensions are +/-50 feet wide by +/-120 feet deep
- Avoid assembly of multiple individual lots to create overly wide singular lots

Resubdivision / Block Sizes:

- In cases where large property assemblages lead to block level resubdivision, use existing prevailing block sizes as a guide
- Existing block sizes vary greatly but the standard typically Oklahoma City intown block is +/-300 feet wide by +/-630 feet long (curb-to-curb)
- Avoid resubdivision efforts that consolidate small blocks into larger blocks
- Be mindful of existing street patterns. Avoid cutting off through streets. Seek opportunities to align new streets with existing adjacent streets
- Avoid creating new cul-de-sacs

Building Set Backs:

- Match prevailing setback of existing houses within the block face
- If the block face does not have a prevailing set back, conform with adjacent blocks or neighborhoods
- Existing setbacks vary block to block but are typically between 20-30 feet

House Widths:

- Match prevailing house widths within the block face
- Existing house widths vary by type and location but a very common width is +/-30 feet

Sidewalks:

- Provide a main sidewalk (one for each unit) that leads directly from the front porch to the public sidewalk (or street curb where no sidewalk exists). Sidewalk width should be minimum 5'-0" and 6'-0" where it touches the curb.
- Sidewalks can have alternate secondary paths to connect to driveways but the driveway should not be the primary pedestrian access point

Foundations:

- Foundation/slab on grade/finish floor height should be 12" min
- Crawl space/finish floor height should be 24" min

Building Orientation:

- All new houses (except for Category F) are required to have a porch or stoop
- Houses should be oriented so that porches, stoops, and doors face the street



2.1 Site Planning Standards

2.1.1 Property and Building Basics

Landscaping:

- Landscaping in the front yard is strongly encouraged including planting beds, foundation planting, yard trees and shrubs
- Front yard landscaping should be used as an accent only and should not serve to block public view of the front yard or largely obstruct the view of the house
- Avoid the use of invasive or exotic species that are not native to the area (e.g., Bamboo)
- Development should include at least one new tree in the front yard per unit developed (min. 2" caliper)

Fencing and Walls:

- Front yard fences/walls may be included at or near the front property line (within 5') in order to delineate front yards from the public sidewalk
- Side yard fences/walls may be included parallel to the front façade of the house running between the house and the side property line in order to delineate the front yard from the side/year yards
- Side yard fences and back yard fences/walls may be included parallel or along the side property line in order to delineate individual lots from one another
- Fences/walls that are located anywhere between the front property line and the front façade of the house (regardless of parallel or perpendicular to the front façade) should be no more than 36" tall
- Fences/walls that are located anywhere behind the front façade of the house should be no more than 72" tall
- Fences/walls – regardless of location – should be decorative in design.
- The following materials are prohibited: concrete, concrete/cinder block, chain link, razor wire, chicken wire or similar



Example of acceptable fencing

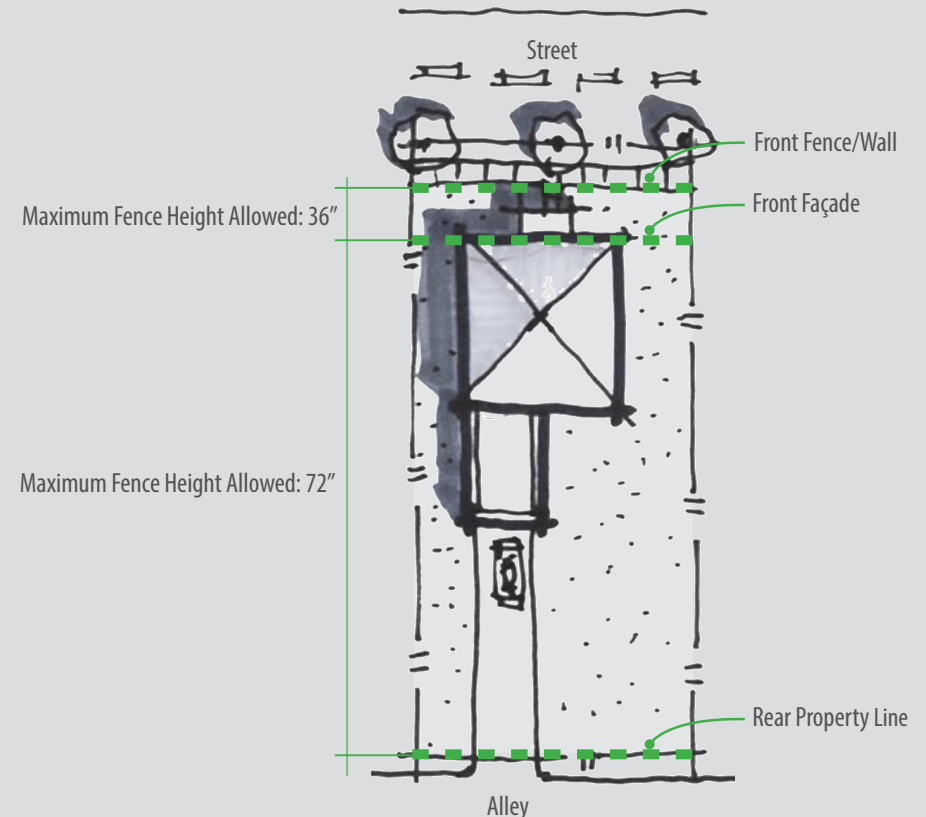

2.1 Site Planning Standards

Examples of acceptable fencing style



Decorative



Height does not block façade



Decorative / Vegetated



Decorative / Vegetated



Pervious

Examples of prohibited fencing style



Prohibited material: chain link



Prohibited material: chain link



Prohibited material: chain link



Prohibited material: cement block



Prohibited material: chain link



Prohibited material: chain link



Height blocks façade



Height blocks façade



2.1 Site Planning Standards

2.1.2 Parking

- Garages should be located on the lot so as to NOT be the dominant physical feature
- Garages can be located to the side or the rear of the primary façade of the house (rear is preferred)
- Primary facades of front-facing garages should be at least 15 feet behind the primary façade of the house
- Rear garages can be attached or detached
- Access garages via mid-block alleys where feasible. In locations where mid-block alleys are possible, driveways connecting to the front/primary street are prohibited
- Driveways should be no more than 10 feet in width for the entire length that extends beyond the primary front façade of the house
- Driveways can widen to up to 18' in width at a point that is behind the line of the primary house façade
- Shared driveways or alleys between lots are encouraged where feasible

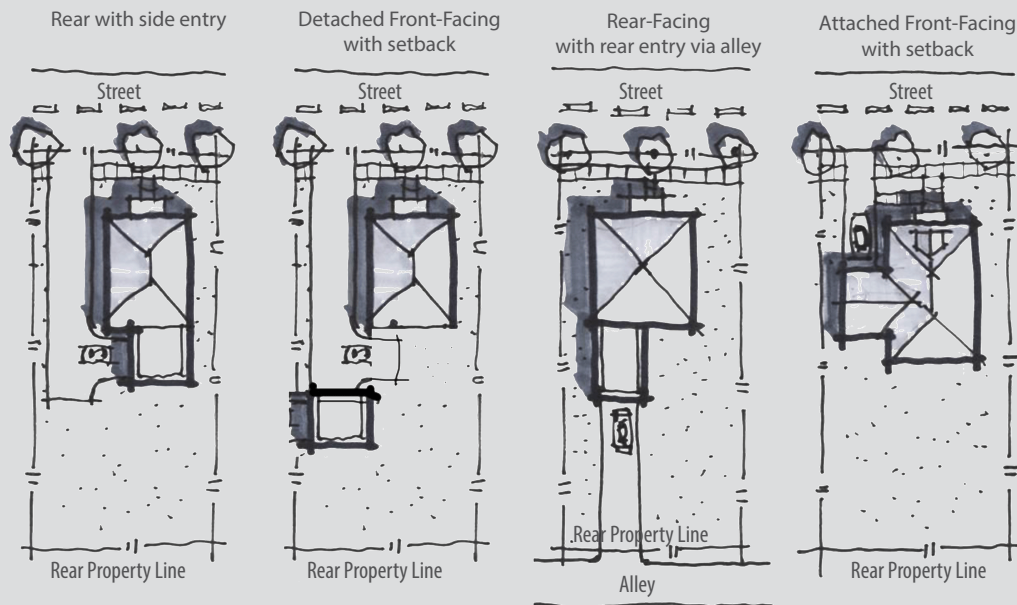

2.2 Architectural Standards

Note: There are numerous variants and exceptions/modifications of the features listed below present in the existing housing categories. These standards are intended to represent the most prototypical to replicate in new housing.

2.2.1 CATEGORY A: The Streetcar Suburban House - Bungalow

A Height

- 1 story

B Roof

- Gable (front or side), Hip, Dutch Hip – primary ridge line
- 4/12 to 6/12 slope
- Same slope on all roofs
- Broad eaves overhang – 2'-0" min.

C Roof Dormers

- Hipped – above eave line only
- Shed – above eave line only

D Façade Symmetry

- Symmetrical – particularly main roof
- Door can be offset

E Front Porch Size / Location

- Full width (or nearly so)
- 5' - 7' min. depth

F Porch Columns

- 16" – 24" brick or stone base
- 8" min. wood columns (can be tapered)

G Side Bays

- Allowed - 3' max. projection
- Box and angled bays

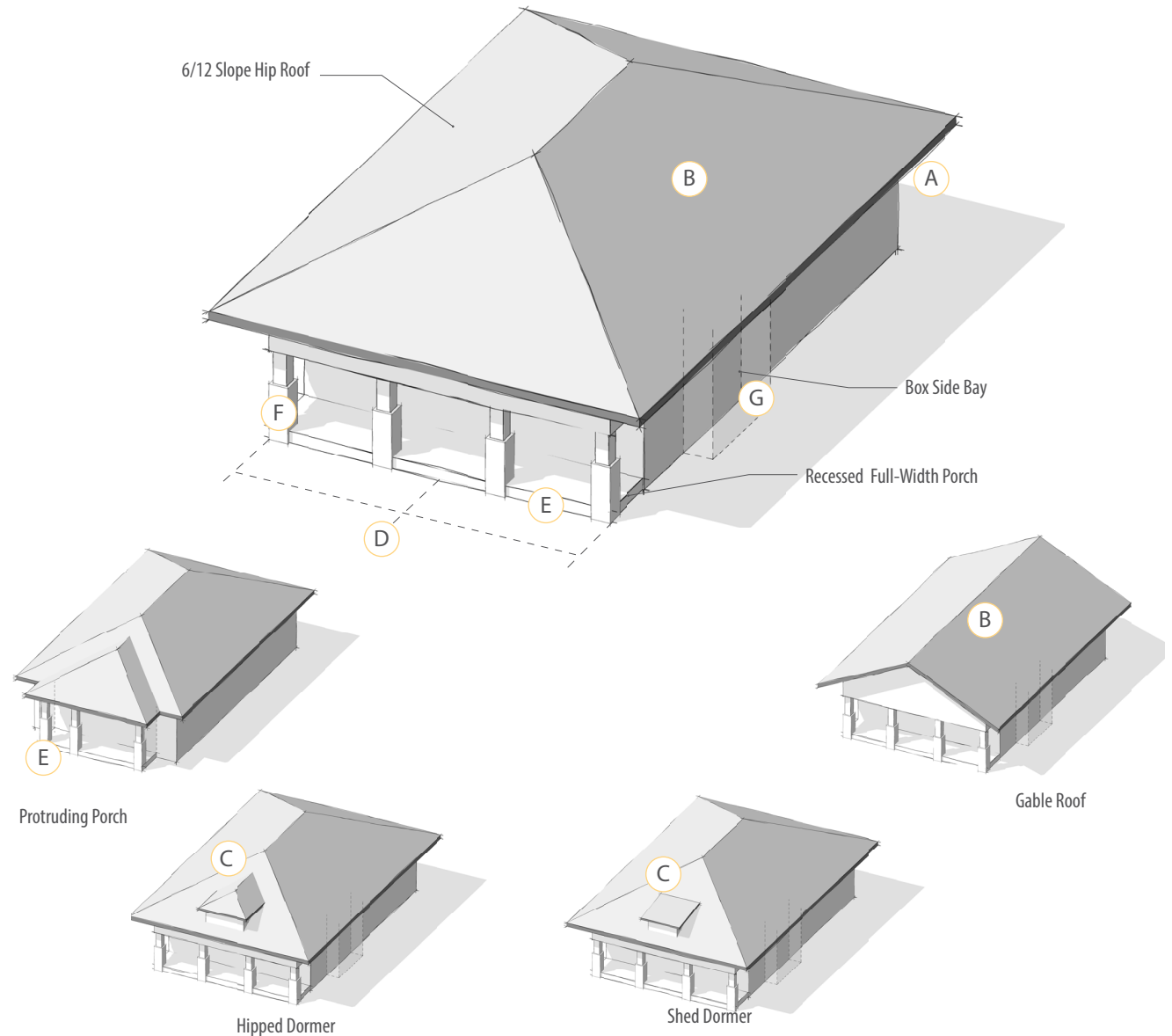

2.2 Architectural Standards

2.2.1 CATEGORY A: The Streetcar Suburban House - Bungalow

H Siding Material

- Brick or stone apron/base
- Full Brick or horizontal lap (wood or cement fiber siding - vinyl or block not allowed)
- Limited board & batten

I Windows/Doors

- Double hung – divided light in upper panel only
- Vertical proportion (2x height/width min.)
- No shutters
- Windows can be grouped – should be separated by a 4" min. mullion board
- Windows should replicate historic pattern and have depth and shadow
- Doors should be appropriately styled
- No grills or bars allowed

J Styling / Details

- Strong Arts & Crafts styling
- Brackets
- Exposed rafter tails
- Gable vents or windows

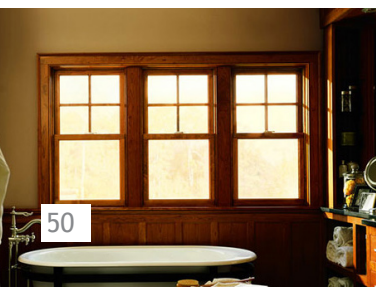

2.2 Architectural Standards

2.2.1 CATEGORY A: The Streetcar Suburban House - Bungalow



2.2 Architectural Standards

Note: There are numerous variants and exceptions/modifications of the features listed below present in the existing housing categories. These standards are intended to represent the most prototypical to replicate in new housing.

2.2.2 CATEGORY B: The Catalogue House - Craftsman Cottage

A Height

- 1 story

B Roof

- Stepped gable – primary ridge line
- Cross gable – primary ridge line
- No Hips (Dutch hips permitted)
- 4/12 to 6/12 slope
- Same slope on all roofs
- Broad eaves overhang – 2'-0" min.

C Roof Dormers

- No dormers

D Façade Symmetry

- Asymmetrical (Stepped gable) – offset porch
- Asymmetrical & symmetrical option (Crossed gable)

E Front Porch Size / Location

- Partial width front porch
- 12' min. width and 5' - 7' min. depth

F Porch Columns

- 8" min. wood columns (can be tapered)

G Side Bays

- Allowed - 3' max. projection
- Box and angled bays

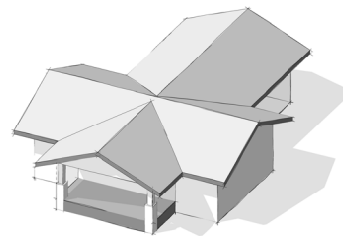
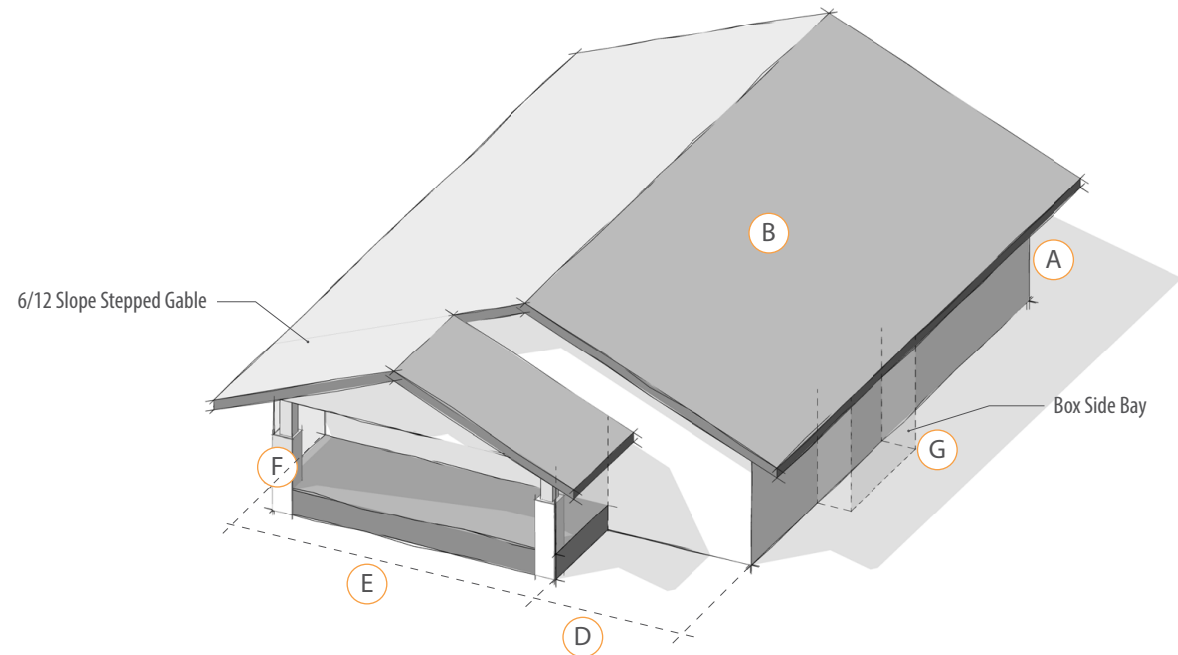

Crossed Gable

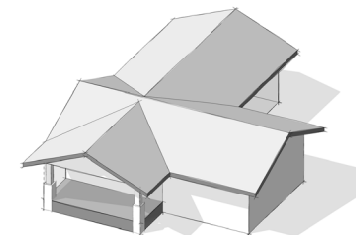

Crossed Gable / Offset Porch

2.2 Architectural Standards

2.2.2 CATEGORY B: The Catalogue House - Craftsman Cottage

H Siding Materials

- Brick or stone apron/base
- Full brick or horizontal lap (wood or cement fiber siding - vinyl or block not allowed) – primary sidings
- Shake shingles / board & batted accent in gables

I Windows/Doors

- Double hung – divided light in upper panels only
- Vertical proportion (2x height/width min.)
- No shutters
- Windows can be grouped – should be separated by a 4" min. mullion board
- Windows should replicate historic pattern and have depth and shadow
- Doors should be appropriately styled
- No grills or bars allowed

J Styling / Details

- Restrained Arts & Crafts styling
- Limited brackets
- Exposed rafter tails



2.2 Architectural Standards

2.2.2 CATEGORY B: The Catalogue House - Craftsman Cottage

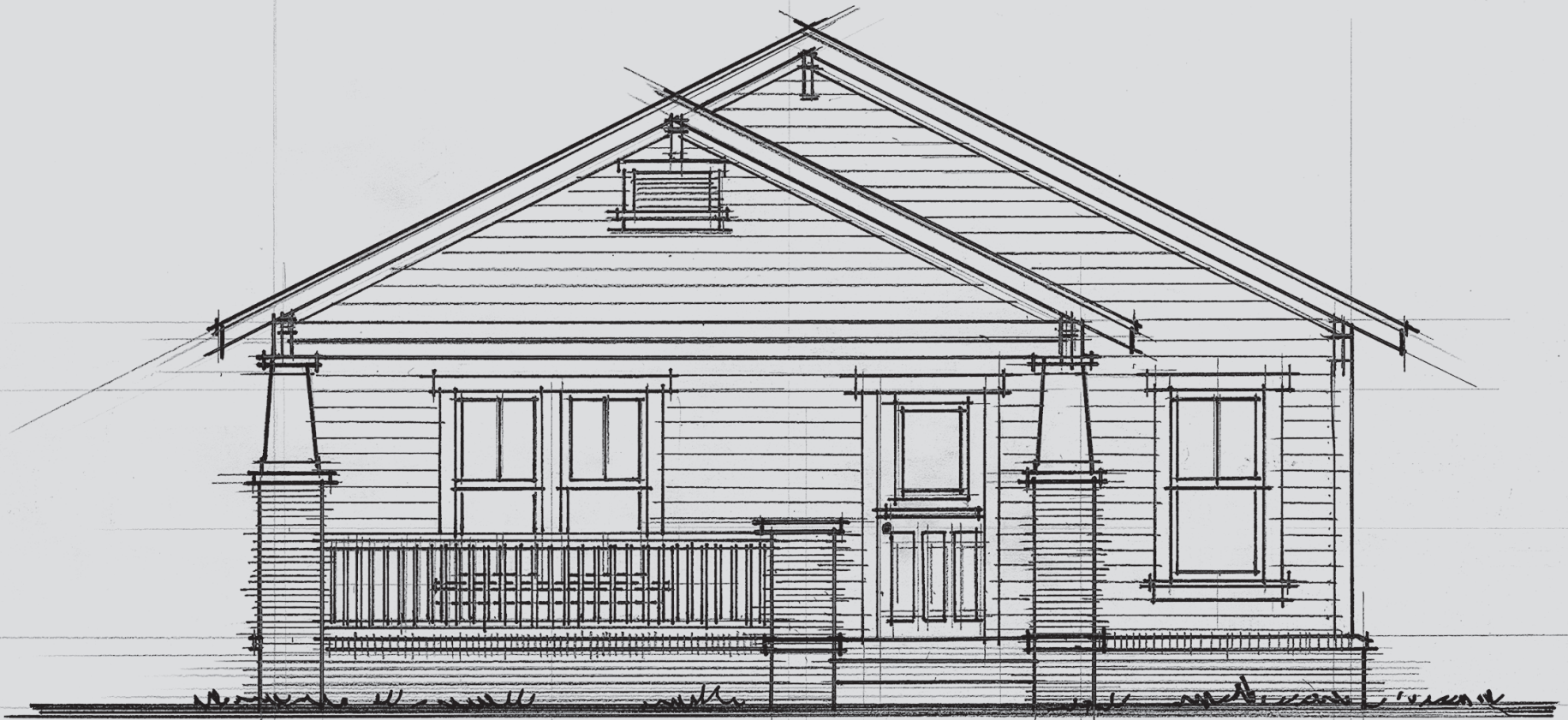

2.2 Architectural Standards

Note: There are numerous variants and exceptions/modifications of the features listed below present in the existing housing categories. These standards are intended to represent the most prototypical to replicate in new housing.

2.2.2 CATEGORY C: The Catalogue House - Tudor Revival

(A) Height

- 1 story

(B) Roof

- Side gable – primary ridge line
- Front gable – accent only
- Asymmetrical front eave line option
- No hips
- 14/12 to 18/12 slope
- Minimum eaves overhang

(C) Roof Dormers

- No dormers

(D) Façade Symmetry

- Asymmetrical – offset transverse gables

(E) Front Porch Size / Location

- Small porch
- Integrated porches only – no separate roof
- 5' - 7' min. depth

(F) Porch Columns

- Minimal quantity
- Integrated into roof / facade

(G) Side Bays

- No bays

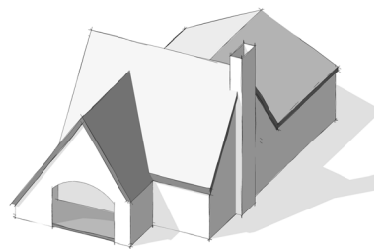
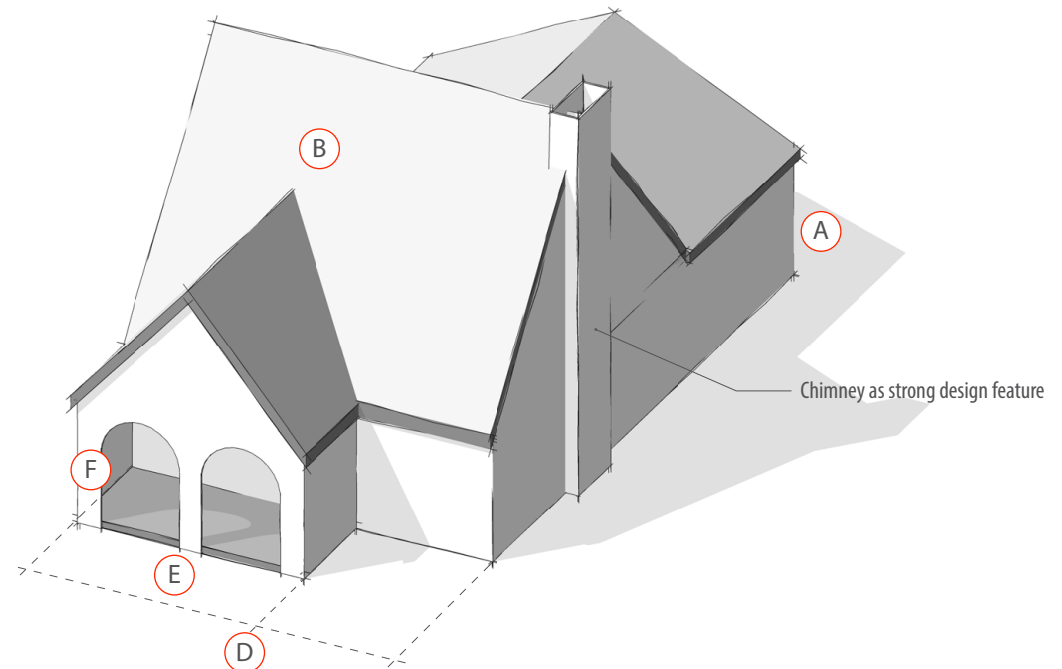

Asymmetrical Front Eave Line

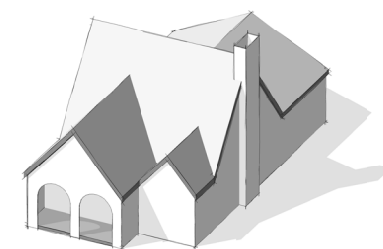

Double Front Gable Accent

2.2 Architectural Standards

2.2.2 CATEGORY C: The Catalogue House - Tudor Revival

H Siding Materials

- Brick or stone (up to eave line min.)
- Optional board & batten gables

I Windows/Doors

- Double hung
- Vertical proportion (2x height/width min.)
- No shutters
- Windows can be grouped – should be separated by a 4" min. mullion board
- Windows should replicate historic pattern and have depth and shadow
- Doors should be appropriately styled
- No grills or bars allowed

J Styling / Details

- Strong Tudor styling
- Chimney as strong design feature encouraged (brick or stone only)
- Minimal roof overhangs



2.2 Architectural Standards

2.2.2 CATEGORY C: The Catalogue House - Tudor Revival

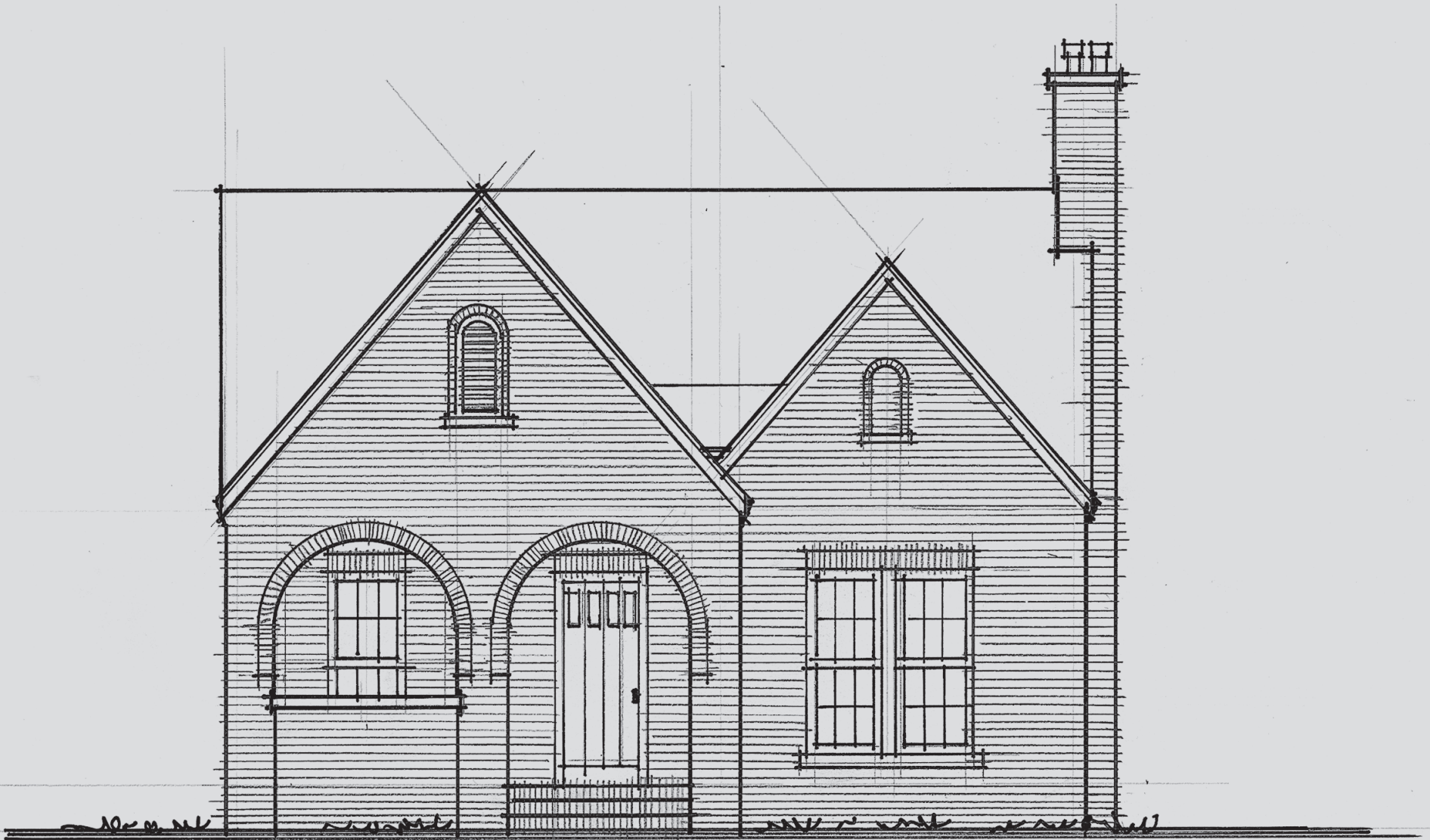

2.2 Architectural Standards

Note: There are numerous variants and exceptions/modifications of the features listed below present in the existing housing categories. These standards are intended to represent the most prototypical to replicate in new housing.

2.2.3 CATEGORY D: The Minimal Traditional House

A Height

- 1 story

B Roof

- Side Gable – primary ridge line
- Small Transverse Gables Optional (1 per façade)
- No Hips
- 4/12 to 8/12
- Smaller eaves overhang – 12" max.

C Roof Dormers

- Gable dormers

D Façade Symmetry

- Symmetrical and asymmetrical options
- Central door, offset bay/front gable

E Front Porch Size / Location

- Small porch
- 8' max. width and 5' - 7' min. depth
- Front gable or shed porch roof

F Porch Columns

- 6" – 8" wood columns (can be tapered)
- Minimal column base

G Side Bays

- Allowed

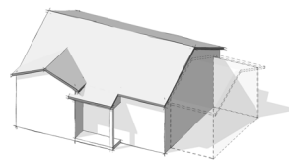
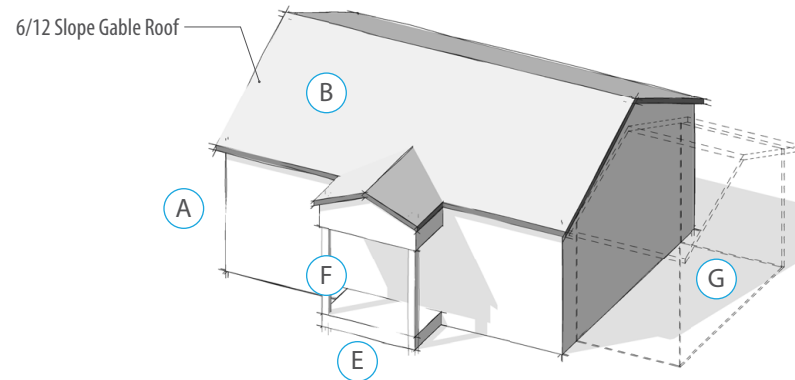

Asymmetrical Façade

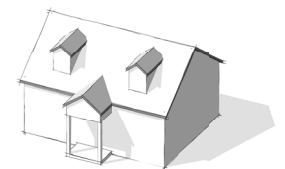

Symmetrical Façade with Dormers

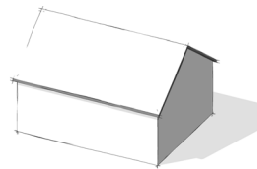

Basic Model

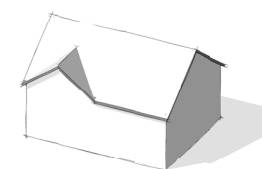

Small Transverse Gable

2.2 Architectural Standards

2.2.3 CATEGORY D: The Minimal Traditional House

H Siding Materials

- Brick or stone apron/base
- Lap siding
- Brick (all sides)

I Windows/Doors

- Double hung – vertical proportion (2x height/width min.)
- Shutters allowed if proportioned to windows
- Windows can be grouped – should be separated by a 4" min. mullion board
- Windows should replicate historic pattern and have depth and shadow
- Doors should be appropriately styled
- No grills or bars allowed

J Styling/Detailing

- Basic Arts & Crafts



2.2 Architectural Standards

2.2.3 CATEGORY D: The Minimal Traditional House



2.2 Architectural Standards

Note: There are numerous variants and exceptions/modifications of the features listed below present in the existing housing categories. These standards are intended to represent the most prototypical to replicate in new housing.

2.2.4 CATEGORY E: The Modern House

A Height

- 1 story

B Roof

- Side gable – primary ridge line
- Hipped – primary ridge line
- No dutch hips
- Emphasis of continuous horizontal eave
- Broad eaves overhang – 2'-6" minimum
- 3/12 to 4/12
- Same slope on all roofs

C Roof Dormers

- No dormers

D Façade Symmetry

- Asymmetrical – offset porch

E Front Porch Size / Location

- Asymmetrical porch (5'- 7' min. depth) or small stoop (4' min. depth)
- Front gable or shed porch roof

F Porch Columns

- 4"-6" wood columns (no tapers)
- Decorative metal

G Side Bays

- Allowed - 3' max. projection

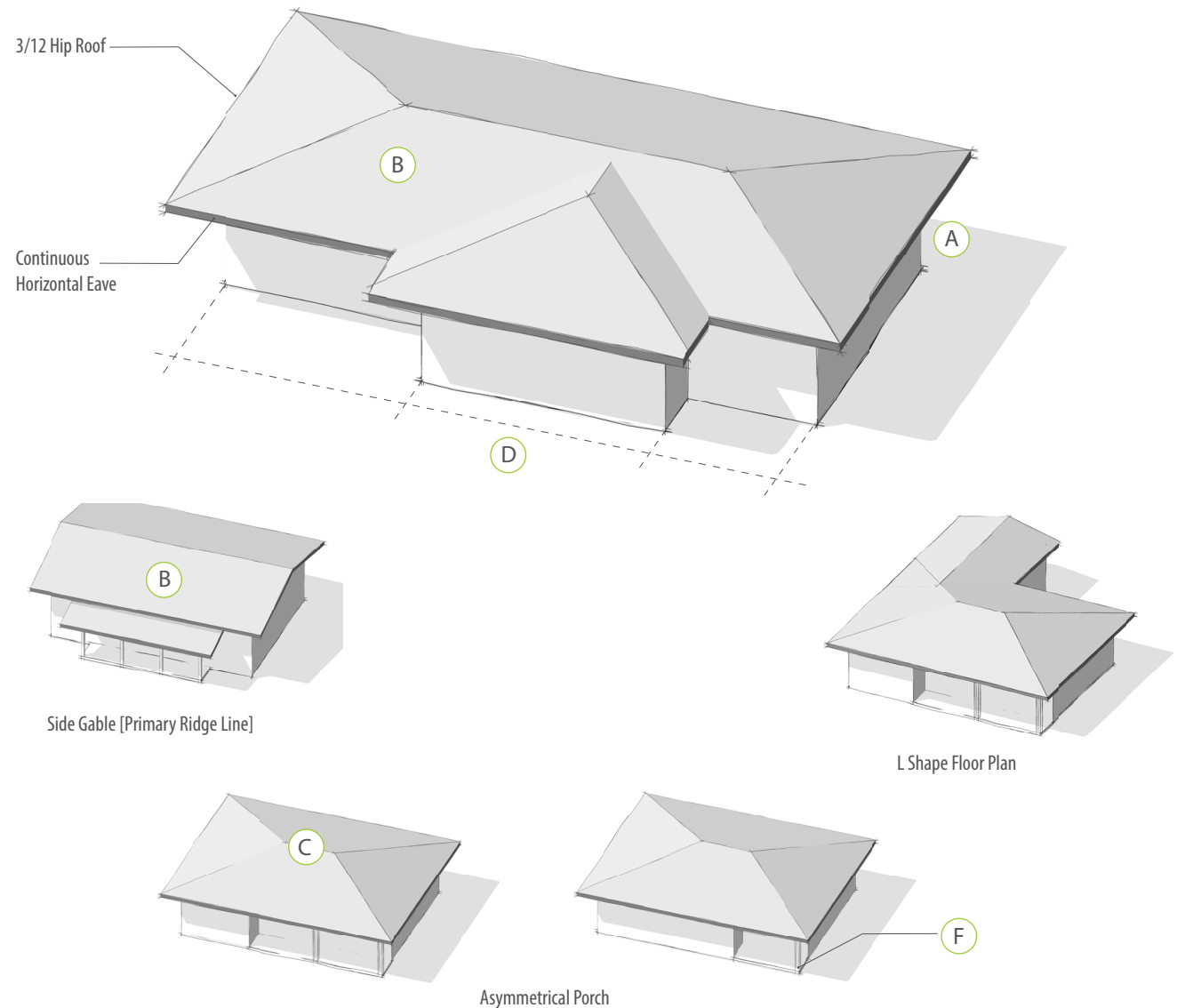

2.2 Architectural Standards

2.2.4 CATEGORY E: The Modern House

H Siding Materials

- Brick or stone (preferably up to eave line)
- Small quantity of lap siding

I Windows/Doors

- Double hung, sliding or casement
- Horizontal proportion (2x width/ height min.)
- Windows can be grouped to achieve horizontal proportion
- Emphasize horizontal sills
- Avoid divided lights
- Doors should be appropriately styled
- No grills or bars allowed

J Styling/Detailing

- Ranch styling
- Horizontal detailing / emphasis



2.2 Architectural Standards

2.2.4 CATEGORY E: The Modern House

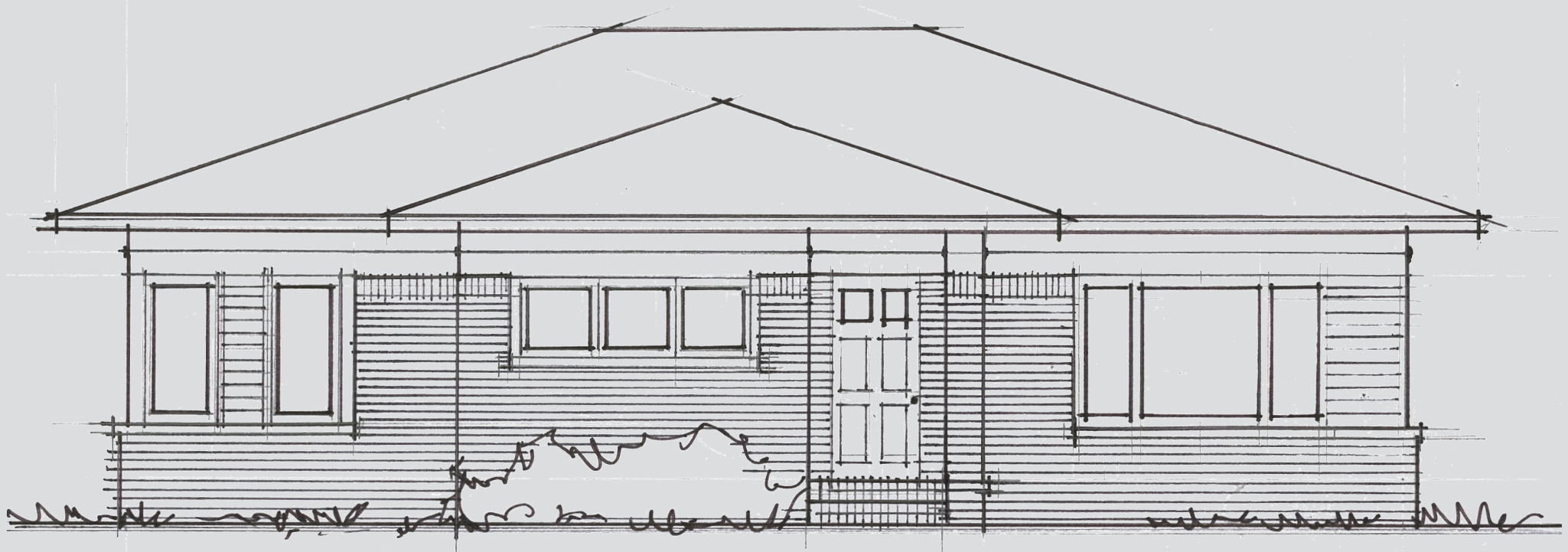

2.2 Architectural Standards

2.2.5 CATEGORY F: The Contemporary House

A Height

- Maximum height not to exceed the height of the ridge line of adjacent homes or the maximum height allowed by zoning within the triangle zone established in Figure 2.2.5.1

B Roof

- Flat or low-pitch roof
- Asymmetrical cross gable
- Low-pitch cross gable (Less than 4/12 slope)
- Shallow shed roof

C Façade Symmetry

- Asymmetrical

D Set Backs

- The front façade plane closest to the street should be set back to match the prevailing setbacks on the block face

E Fenestrations and Orientation

- The front façade should create an inviting presence to the street including a visible front door.
- At least 30% of the front façade should include fenestrations

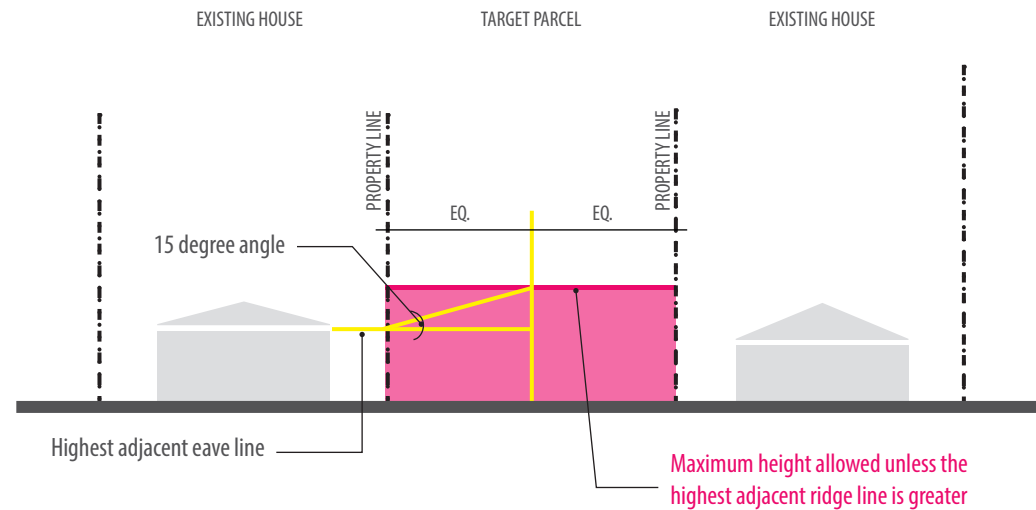

FIGURE 2.2.5.1

F Exterior Finishes

- Brick, stone, wood, glass. Limited amounts of concrete, metal, and stucco surfaces (Maximum 20% of entire façade). It should be detailed and finished in a high quality manner and be integral to the design of the home. Exposed cement block is not permitted.

2.2 Architectural Standards

2.2.5 CATEGORY F: The Contemporary House



An aerial photograph of a city grid, showing streets, buildings, and trees. A green banner is overlaid across the middle of the image, containing the text '3.0 The Design Review Process'.

3.0 The Design Review Process

3.1 Choosing Your Architectural Category

In choosing your architectural category, it is essential to have a meeting with OCURA early on to determine what may or may not be allowed on the target parcel(s). In general, the following guidelines apply:

Infill Housing

Infill Housing is defined for this document as any house built on a vacant parcel located on a block face where 60% or more of the block face is already built. To determine an architectural category for infill housing, identify the categories that exist on the block face (and the block face across the street) of the parcel in question. The new construction can be any of the established categories. In areas where the majority or the only existing category is the *Postmodern House*, all categories (Categories A through F) are allowed.

Case Scenario

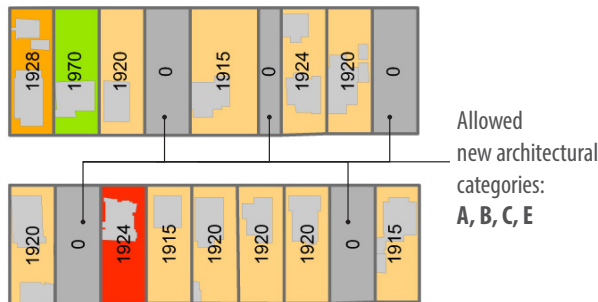

New subdivision development

New subdivision development is defined for this document as the construction of multiple houses (incrementally or otherwise) on a vacant parcel(s) where 60% or more of the block face is not built. Any of the architectural categories incorporated in Chapter 2 (Categories A through F) can be used for a new subdivision development as long as the chosen category(-ies) adheres to the site and architectural standards outlined in Chapter 2.

Case Scenario

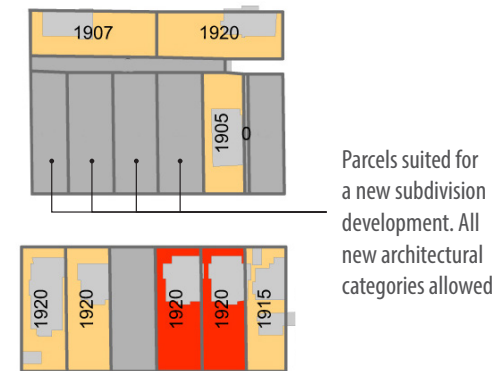

EXISTING ARCHITECTURAL CATEGORIES

| | | |
|--|---|--------|
| | THE STREET CAR SUBURBAN HOUSE |> |
| | BUNGALOW |> |
| | AMERICAN FOURSQUARE |> |
| | NATIONAL |> |
| | TWO-FAMILY DWELLINGS |> |
| | THE CATALOGUE HOUSE - CRAFTSMAN COTTAGE |> |
| | THE CATALOGUE HOUSE - TUDOR REVIVAL |> |
| | THE MINIMAL TRADITIONAL HOUSE |> |
| | THE MODERN HOUSE |> |
| | THE POSTMODERN HOUSE |> |
| | THE NEW ECLECTIC HOUSE |> |
| | THE CONTEMPORARY HOUSE |> |

CORRESPONDING NEW ARCHITECTURAL CATEGORY

| | |
|--|---|
| | CATEGORY A: THE STREET CAR SUBURBAN HOUSE - BUNGALOW |
| | DEALT ON A CASE-BY-CASE BASIS |
| | DEALT ON A CASE-BY-CASE BASIS |
| | DEALT ON A CASE-BY-CASE BASIS |
| | CATEGORY B: THE CATALOGUE HOUSE - CRAFTSMAN COTTAGE |
| | CATEGORY C: THE CATALOGUE HOUSE - TUDOR REVIVAL |
| | CATEGORY D: THE MINIMAL TRADITIONAL |
| | CATEGORY E: THE MODERN HOUSE |
| | NONE |
| | CATEGORY F: THE CONTEMPORARY HOUSE |

3.2 Design Review

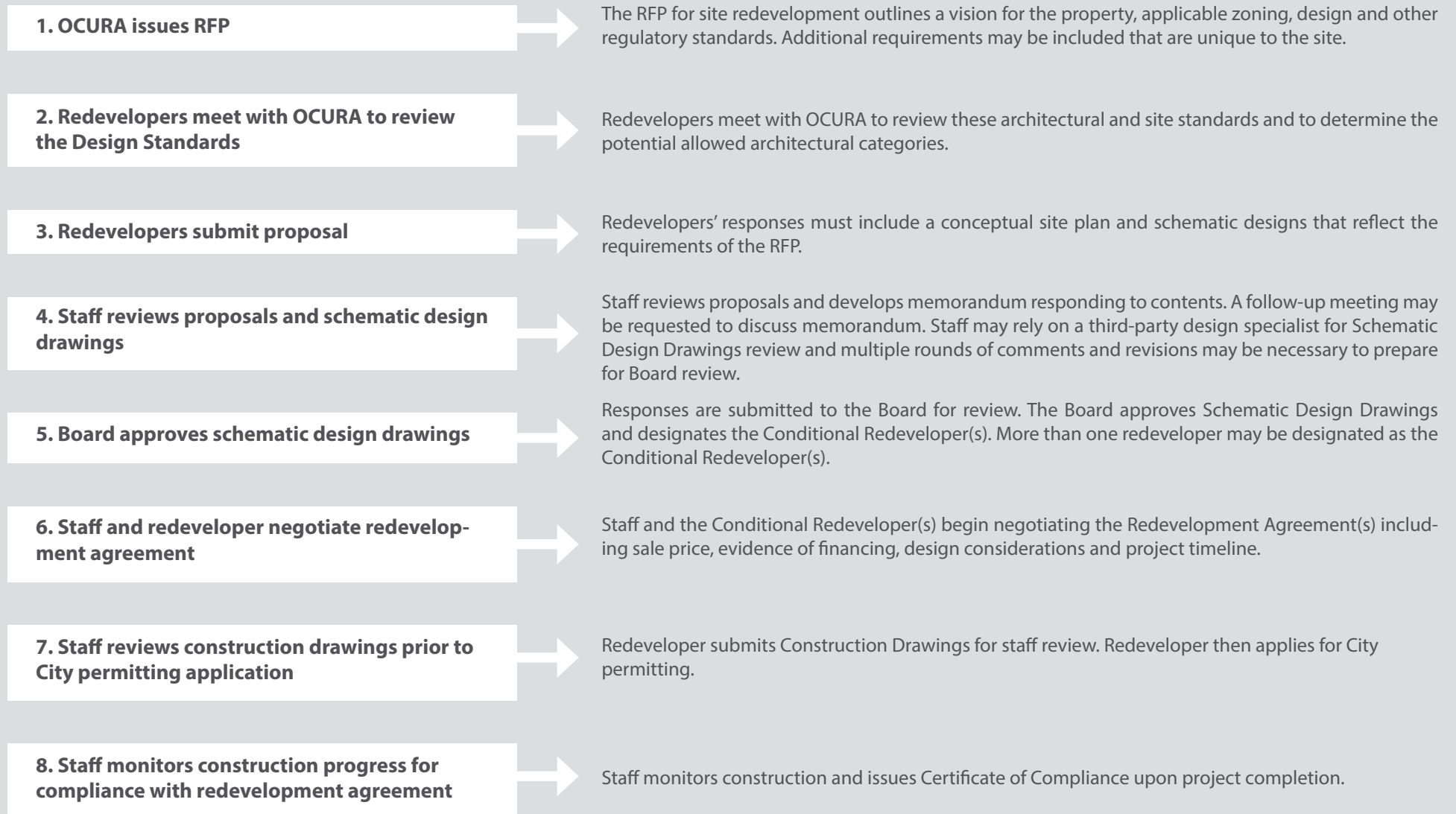

Image Sources

Unless listed here, all images used in this document were taken by Lord Aeck Sargent during various existing conditions surveys performed during 2014.

| | |
|------------------|---|
| Image 1A: | Oklahoma Historical Society digital archives |
| Image 1B: | Oklahoma Historical Society digital archives |
| Image 1C: | www.thegreatamericangrid.com |
| Image 1D: | Kathleen Mauck Collection, Oklahoma Historical Society |
| Image 1E: | Kathleen Mauck Collection, Oklahoma Historical Society |
| Image 1F: | Doug Dawgz Oklahoma City blog |
| Image 1G: | John J. Harden Collection, Oklahoma Historical Society |
| Image 1H: | Sears online archives (http://www.searsarchives.com/) |
| Image 1I: | Carolyn Cuskey, Midwest City Historical Photos online collection |
| Image 1J: | Digital archive, Prelinger Library, San Francisco |
| Image 1M: | Ray Jacoby Collection, Oklahoma Historical Society |
| Image 1N top: | http://en.wikipedia.org/wiki/Winslow_Ames_House |
| Image 1N bottom: | Google Street View |
| Image 1P: | The American Motohome catalogue |
| Image 1Q: | Oklahoma Historic Center archives |
| Image 1R: | Oklahoma Historic Center archives |
| Image 1S: | Internet images from various kit house manufacturer's catalogues |
| Image 1T: | www.cabincreekcds.com/searshnrbilt30.htm |
| Image 1U: | Internet images from various kit house manufacturer's catalogues |
| Image 1V: | Oklahoma History Center Archives, John Harden Folder |
| Image 1W: | Internet images from various kit house manufacturer's catalogues |
| Image 1X: | www.okcmod.com |
| Image 1Y: | Dr. Ruth Colbert Barnes |
| Image 1Z: | Google Street View |
| Image 1ZZ: | Google Street View and www.concretedesignblog.com |

Page 47

www.dailyhomedecorideas.com
www.schmidtfenceanddeck.com
www.mikebara.com
www.windowpro.com
www.idealhomegarden.com
www.hookedonhouses.net

Page 50

www.marvinwindowstore.com
www.andersenwindows.com
www.windowpro.com
www.pinterest.com
www.houzz.com
www.panoramio.com

Page 53

www.positivelypaseo.org
www.centsationalgirl.com
www.calbungalow.com
www.eplans.com

Page 56

www.thefhd.net
www.ericas2blog.wordpress.com
www.insidearciform.com
www.historichousecolors.com
www.atlantaexecutivehomes.com
www.patch.com

Page 59

www.hgtvhome.com
www.dot.ga.gov
www.interior-idea.com

Page 62

www.hibbshomes.com
www.hookedonhouses.com
www.barbarasimonlandscapedesign.com
www.swamplot.com
www.activerain.trulia.com

Page 65

www.activerain.trulia.com
www.homebuilding.co.uk
www.finehomebuilding.com
www.korerealestate.com/spruce-cliff-homes-for-sale.php
www.onekindesign.com
Google Street View